

DOCUMENT RESUME

ED 204 109

SE 035 049

AUTHOR Baki, Peggy, Ed.; And Others.
TITLE Electrical Installation and Maintenance: A Competency-Based Curriculum Manual.
INSTITUTION North Carolina State Dept. of Community Colleges, Raleigh. Occupational Program Services.
SPONS AGENCY Department of Energy, Washington, D.C.; North Carolina State Dept. of Commerce, Raleigh. Energy Div.
PUB DATE 80
NOTE 143p.
EDRS PRICE MF01/PC06 Plus Postage.
DESCRIPTORS Building Trades; *Competency Based Education; *Curriculum Development; Electrical Occupations; *Electrical Systems; *Electricians; Postsecondary Education; Task Analysis; Technical Education; *Trade and Industrial Education

ABSTRACT

Described is a competency-based community college curriculum for programs in electrical installation and maintenance. The initial curriculum development project involved identifying career opportunities, determining the skills (tasks) required for each job, and analyzing each task for necessary competencies and performance criteria. Project participants then developed a curriculum model and guidelines. Presented in this document are the resulting task analyses and curriculum guide. In the task analysis section, 17 tasks are delineated by subtasks, competencies and evaluation criteria. The curriculum guide section provides a model for a four-quarter sequence designed to prepare individuals to enter employment with electrical contracting firms as advanced-level apprentices with the basic skills and knowledge of electrical installations. (Author/WB)

* Reproductions supplied by EDRS are the best that can be made *
* from the original document. *

ED204109

ELECTRICAL INSTALLATION and MAINTENANCE

A Competency-Based Curriculum Manual

PERMISSION TO REPRODUCE THIS
MATERIAL HAS BEEN GRANTED BY

A. V. BEVACQUA

TO THE EDUCATIONAL RESOURCES
INFORMATION CENTER (ERIC)

U.S. DEPARTMENT OF HEALTH
EDUCATION & WELFARE
NATIONAL INSTITUTE OF
EDUCATION

U.S. GOVERNMENT PRINTING OFFICE
1975 O - 222-100-0000

PROGRAM DEVELOPMENT
DEPARTMENT OF
COMMUNITY COLLEGES
RALEIGH, NORTH CAROLINA

SE 035 049

ELECTRICAL INSTALLATION AND MAINTENANCE
A COMPETENCY-BASED CURRICULUM MANUAL

Winter 1980

Prepared for

Energy Conservation Curriculum and Short Course Project #8208

Project Director:
Roger G. Worthington

Curriculum Coordinator:
Dr. Larry W. Fuqua

Project Coordinator:
Peggy M. Ball

Sponsored by North Carolina Department of Community Colleges,
in cooperation with the North Carolina Energy Division, with
funds granted by the United States Department of Energy (DOE)
pursuant to the provisions of the Energy Policy and Conserva-
tion Act (EPCA) PL 94-163, and/or the Energy Conservation and
Product Act (ECPA) PL 94-385.

OCCUPATIONAL PROGRAM SERVICES
(FORMERLY PROGRAM DEVELOPMENT SECTION)
DEPARTMENT OF COMMUNITY COLLEGES
RALEIGH, NORTH CAROLINA

EQUAL OPPORTUNITY AND AFFIRMATIVE ACTION INSTITUTIONS

It is the policy of the Community College System not to discriminate on the basis of race, sex, age, national origin, religion, or handicap with regard to its students, employees, or applicants for admission or employment.

FOREWORD

The Department of Community Colleges and the State Board of Community Colleges encourage the institutions in the System to maintain high-quality educational standards to assure that those who avail themselves of the educational opportunities offered in the System are prepared to meet the requirements of the jobs for which they train. To assure high-quality educational programs the State Board has instructed the Department to assist the institutions in the development of the competencies for each educational curriculum.

This document presents the job opportunities and competencies identified as those appropriate to the Electrical Installation and Maintenance curriculum offered in the Community College System. The materials included are the results of the involvement of employers, employees, and educators.

This material is to be considered as a minimum standard. The material should provide guidance as a model to assist the curriculum planners in the institution in the development of the curriculum. Each institution offering an Electrical Installation and Maintenance curriculum is encouraged to organize and involve an advisory committee composed of employers and employees in the electrical construction industry in the adaptation of these materials to the area being served.

ACKNOWLEDGEMENTS

The development of this publication required the advice, dedication, and hard work of many persons who gave many hours of their time to writing, revising, and rewriting the materials included herein. A curriculum committee of instructors coordinated by Dr. Larry Fuqua provided valuable assistance in developing the career opportunity survey and an initial list of tasks. A workshop held by the Department for the instructors in the Electrical Installation and Maintenance curriculums from the Community College System gave the instructors an opportunity to critique and evaluate the materials. Many valuable and constructive suggestions were received during the workshop, and these suggestions were incorporated into this manual.

The writing of the task analyses was done primarily by Mr. John W. McKeel, a consultant writer to the Department. We appreciate Mr. McKeel's assistance with this project and particularly his counsel based on his expert knowledge of the National Electrical Code and his extensive experience in the field of electrical installation.

Ms. Peggy Ball, Program Coordinator, Department of Community Colleges, edited, organized, and guided the development of this manual in her role as coordinator of an Energy Conservation and Short Course Project (#8208) funded to the Department by the North Carolina Energy Division.

The Department recognizes herein those who were members of the curriculum committee and those who attended the curriculum workshop. This recognition is not to imply their endorsement in part or in whole of this manual but to express appreciation to each for interest in improving the educational programs in the System.

The Curriculum Committee

Mr. Rudee Boan
Mitchell Community College

Mr. Norman Lackey
Catawba Valley Technical College

Mr. Ben Burril
McDowell Technical College

Mr. Pete Oakes
Fayetteville Technical Institute

Mr. Stephen Herman
Randolph Technical College

Mr. Bernard Smith
Craven Community College

Dr. Larry Fuqua
Department of Community Colleges

Mr. Arville Stanley
Stanly Technical College

Mr. James Kinard
Gaston College

Evaluation Workshop Participants

Elton Leon Dillard
Vance-Granville Community College

Kent Priddy
Caldwell Community College and
Technical Institute

Franklin Griffin
Catawba Valley Technical College

Burton Harris
Isothermal Community College

Stephen Herman
Randolph Technical College

Ronald Ingle
Piedmont Technical College

James A. Kinard
Gaston College

Oscar Lambert
James Sprunt Technical College

Howard Lawrence
Wake Technical College

Eugene Madison
Robeson Technical College

John W. McKeel
Bryant Electric Company, Inc.

Vohn Peeler
Rowan Technical College

Leland Pittman
Wilson County Technical Institute

Robert Leland Pittman
Nash Technical Institute

Gary Shaw
Southeastern Community College

Jimmie L. Sigmon
Gaston College

David Singletary
Bladen Technical College

Julian Lennon Singletary
Bladen Technical College

William Randolph Smith
James Sprunt Technical College

Richmond Dick Statham
Guilford Technical Institute

Jarvis Tripp
Pitt Community College

Glenwood Waters
Martin Community College

Andrew Thomas Wrench
Sampson Technical College

Appreciation is also expressed to Mr. Bill Pugh for the cover art and to Mrs. Vickie Cozart and Ms. Brenda Crowder for technical assistance.

The Writing and Editing Committee

A special writing and editing committee was established to review, edit, and rewrite all the competency-based curriculum materials. This committee's role was to insure that all the materials were written in the same style and format, and to carefully edit for consistency and correctness of all materials. The Community College System is indebted to them for their dedication and sincere efforts.

Ms. Peggy Ball

Mr. John W. McKeel

CONTENTS

	Page
CHAPTER I - Introduction	1
Methodology of Curriculum Development Project	1
Career Opportunity Survey	2
Task Analysis Process	4
CHAPTER II - Task Analysis	7
Service Entrances	13
Feeders	19
Panelboards and Switchboards	25
Duct Systems	27
Grounding	31
Branch Circuits	37
Low Voltage Control Systems	51
Signal Systems	53
Transformers	55
Electric Heating	57
Motors and Controls	61
Maintenance	69
Hazardous Locations	87
Load Calculations	89
Blueprint Reading and Estimating	95
Rehabilitation Work and Adding Circuits	107
Special Occupancies and Equipment	109
CHAPTER III - Curriculum Guide	111
Curriculum and Job Description	113
Curriculum Model	115
Tasks: Electrical Installation and Maintenance	117
Course Descriptions with Task Listing	
First Quarter	
ELC 1112 Directing and Alternating Current	121
ENG 1101 Reading Improvement	123
MAT 1115 Electrical Mathematics	125
PHY 1101 Applied Science	127
Second Quarter	
ELC 1113 Alternating Current and Direct Current	
Machines and Controls	129
DFT 1110 Blueprint Reading: Building Trades	131
ENG 1102 Communication Skills	133

	Page
PHY 1102 Applied Science	135
Third Quarter	
ELC 1124 Residential Wiring	137
ELN 1118 Industrial Electronics	139
PSY 1101 Human Relations	141
DFT 1113 Blueprint Reading: Electrical	143
Fourth Quarter	
ELC 1125 Commercial and Industrial Wiring	145
ELN 1119 Industrial Electronics	149
BUS 1103 Small Business Operations	151

APPENDICES

	Page
A. Career Opportunity Survey	
1. Introductory Letter	155
2. Survey Form	157
3. Survey Results	158
B. Electrical Installation and Maintenance Workshop Program	161
C. Basic Electrical Equipment List	163
D. Supplementary Materials	173
E. Definition of Terms	185

CHAPTER I

INTRDDUCTION

In 1976, the Program Development Section (now the Occupational Program Services Section), Department of Community Colleges, designed a competency-based curriculum development project using the task analysis technique as a proposal for the development of technical and vocational curriculums offered in the Community College System. This project was designed to involve employers, employees, and educators through the use of surveys, curriculum committees, and advisory committees in determining the jobs and competencies for a given curriculum under study. The task analysis technique produces a model curriculum and guidelines based upon input from employers, employees, and educators which institutions can use in establishing or evaluating their curriculum.

In determining curriculums to be studied as a part of the competency-based curriculum development project, the Electrical Installation and Maintenance curriculum was chosen because of recent rapid changes in the industry. Since the early 1960's, Electrical Installation and Maintenance curriculums have been offered in the System. These curriculums were designed to prepare individuals to enter employment with electrical contracting firms as advanced-level apprentices with the basic skills and knowledge of electrical installation. Each program throughout the System has strived to be responsive to the needs of local employers and to keep abreast of changes in the industry. In recent years, some of these changes have developed at a pace that has made it necessary to review the curriculum to assure that students leaving the program have skills and knowledge applicable to today's employment needs.

METHDDODOLOGY OF CURRICULUM DEVELOPMENT PROJECT

Procedure:

Competencies necessary for successful employment in electrical installation and maintenance occupations were identified as a response to the following concerns:

1. Quality instruction that assures that an individual completing a curriculum is prepared for employment;
2. Articulation between secondary and post-secondary vocational-technical curriculums;
3. Involvement of employers, employees and educators in curriculum development; and
4. Assurance that curricula are up-to-date in accordance with current job technology requirements.

In response to these concerns the curriculum revision process provided (1) a validated list of career (job) opportunities for which the

curriculum provides training and education; (2) the tasks performed by employees in each job; (3) a list of competencies and evaluative criteria essential to successful performance on the job; and (4) a model curriculum.

Phases:

The procedure for conducting this project was accomplished in five phases:

- Phase I of the project identified the curriculums for which competencies were to be developed. Electrical Installation and Maintenance, V-018, was selected from the building trades curricula currently offered in the North Carolina Community College System.
- Phase II of the project was a search for existing competency-based curriculum materials. These materials were used as resources in writing the materials herein.
- Phase III of the project identified and validated the career opportunities (job titles) currently used by the electricians. The career opportunities were identified from the Dictionary of Occupational Titles and by employers and validated through a career opportunity survey of employers.

A job analysis was made to determine the tasks the person performs in carrying out the functions of the job.

Phase IV of the project analyzed each task to determine necessary competencies and criteria for measuring performance.

Phase V of the project was the development of a curriculum model and suggested guidelines for the curriculum.

CAREER OPPORTUNITY SURVEY

Phase III of the project, the career opportunity survey, was the first phase in which employers, employees, and instructors in the Community College System were directly involved in the project. A survey was conducted to identify job titles appropriate for this curriculum and to identify employment opportunities within North Carolina. A curriculum committee of instructors provided information for preparation of the survey and helped identify the subjects of the survey. The survey was sent to electrical contractors. (See Appendix A for example of survey.)

The following job titles were surveyed and determined to be appropriate. The descriptions given below are taken from the Dictionary of Occupational Titles, Fourth Edition.

824.261-014 ELECTRICIAN APPRENTICE (any ind.) (see APPRENTICE, any ind.)

A worker who learns, according to written or oral contractual agreement, a recognized skilled craft or trade requiring one or more years of on-the-job training through job experience supplemented by related instruction, prior to being considered a qualified skilled worker. High

school or vocational school education is often a prerequisite for entry into an apprenticeship program. Provisions of apprenticeship agreement regularly include length of apprenticeship; a progressive scale of wages; work processes to be taught; and amount of instruction in subjects related to the craft or trade, such as characteristics of materials used, physics, mathematics, estimating, and blueprint reading. Apprenticeship ability for registration as a trade by a State apprenticeship agency or the Federal Bureau of Apprenticeship and Training. Generally, where employees are represented by a union, apprenticeship programs come under the guidance of joint apprenticeship committees composed of representatives of the employers or the employer association and representatives of the employees. These committees may determine need for apprentices in a locality and establish minimum apprenticeship standards of education, experience, and training. In instances where committees do not exist, apprenticeship agreement is made between apprentice and employer, or an employer group. The title, APPRENTICE, is often loosely used as a synonym for beginner, HELPER (any ind.), or TRAINEE (any ind.). This practice is technically incorrect and leads to confusion in determining what is meant. Typical classifications for apprentices are BLACKSMITH APPRENTICE (forging); MACHINIST APPRENTICE (mach. shop); and PLUMBER APPRENTICE (const.).

829.684-022 ELECTRICIAN HELPER (any ind.) wirer helper.

Assists ELECTRICIAN (any ind.) to install and repair electrical wiring, fixtures, and equipment, performing any combination of following tasks: Measures, cuts, and bends wire and conduit, using ruler and handtools. Drills holes for wiring, using power drill, and pulls or pushes wiring through opening. Assists in lifting, positioning, and fastening objects, such as wiring, conduit, and motors. Performs minor repairs, such as replacing fuses, tight sockets, bulbs, and switches, using handtools. Maintains tools and equipment and keeps supplies and parts in order. Disassembles defective electrical equipment, such as motors, using handtools. Performs other duties as described under HELPER (any ind.).

824.261-010 ELECTRICIAN (any ind.) wirer.

Plans, lays out, installs and repairs wiring, electrical fixtures, apparatus, and control equipment. Plans new or modified installations to minimize waste of materials; provide access for future maintenance, and avoid unsightly, hazardous, and unfeltable wiring, consistent with specifications and local electrical codes. Prepares sketches showing location of wiring and equipment, or follows diagrams or blueprints, insuring that concealed wiring is installed before completion of future walls, ceilings, and flooring. Measures, cuts, bends, threads, assembles, and installs electrical conduit, using such tools as hacksaw, pipe threader, and conduit bender. Pulls wiring through conduit, assisted by ELECTRICIAN HELPER (any ind.). Splices wiring by stripping insulation from terminal leads with knife or pliers, twisting or soldering wires together, and applying tape or terminal caps. Connects wiring to lighting fixtures and power equipment; using handtools. Installs control and distribution

apparatus, such as switches, relays, and circuit-breaker panels, fastening in place with screws or bolts, using handtools and power tools. Connects power cables to equipment, such as electric range or motor, and installs grounding leads. Tests continuity of circuit to insure electrical compatibility and safety of components, using testing instruments, such as ohmmeter, battery and buzzer, and oscilloscope. Observes functioning of installed equipment or system to detect hazards and need for adjustments, relocation, or replacement. May repair faulty equipment or systems [ELECTRICAL REPAIRER (any ind.)]. May be required to hold license. May cut and weld steel structural members, using flamecutting and welding equipment. May be designated according to work location as MINE ELECTRICIAN. (mining & quarrying).

The survey results indicated that opportunities exist for the job titles surveyed. In addition, other job titles were suggested. (See Appendix A for results of survey.)

TASK ANALYSIS PROCESS

The task listing was prepared using the results of the career opportunity survey to determine the jobs to be examined. The performance of these jobs was analyzed to determine the general tasks executed on the job. These tasks were organized into broad task areas and specific sub-tasks were written for each task.

A competency statement was then written for each task to indicate the degree of proficiency to which a task must be performed. Criterion measures were written to establish standards to be used to judge competence in performance of a task.

The completed task listing, competencies, and criterion measures were presented at a workshop for electrical instructors from community colleges and technical institutes/colleges offering the Electrical Installation and Maintenance curriculum. Twenty-two instructors attended, representing 44% of the schools offering this program. (43 schools, 19 represented.) (See Appendix B for workshop program.)

These instructors were asked to evaluate the tasks, sub-tasks, competencies and criterion measures. The evaluation included the following:

1. Analysis of task areas, tasks and sub-tasks to determine if they were appropriate and necessary.
2. Analysis of competencies and criterion measures to determine if they were relevant to tasks
3. Analysis of suggested courses in curriculum model to determine which tasks should be taught, in which courses.

The task listing with sub-tasks, competencies and criterion measures presented in Chapter II and the task listing by courses in Chapter III are based upon the instructors' evaluations and recommendations. Even though there was not unanimous agreement on all parts of the task analysis, the task listing that is used in this manual reflects as nearly as possible the suggestions and ideas of the instructors at the evaluation workshop.

CHAPTER II

TASK ANALYSIS

The following listings of tasks, sub-tasks, competencies, and criterion measures are intended to serve as guides in developing or revising a curriculum. Each institution should very carefully review the task analyses. They should then involve an active advisory committee of employers and employees from the area the institution serves to advise them in planning the curriculum. The advisory committee can give advice on organization and emphasis to be placed on a task and can help to decide on the hierarchical order of importance for teaching each task. The instructors should determine the courses to be taught, the sequence and length of the courses and which tasks are to be taught in each course.

Tasks:

The task listing indicates the expectations of the employer. The task analysis provides to the educator the information needed to determine the knowledge and skills to be taught.

Two riser diagrams, one of a typical house and one of a typical plant, were used as the basis for determining the task areas and the sequence for the task analysis. These task areas, beginning with the service entrance, were then used to develop the tasks necessary to complete an electrical installation similar to the diagrams on the following pages.

Competencies:

Each task was restated as a competency statement. The competency statement defines the degree of accuracy and/or proficiency the employee should attain in performing the assigned task. The competencies, as well as the tasks, are written to reflect the level of performance necessary for the employee to be successful on the job. The employee should be able to perform the task at the competency level as measured by the criterion.

Criteria:

The criteria for each competency were stated as a measure of what the employee can do in carrying out the assigned task to the level of competency stated. These criteria are used to judge success or degree of accuracy to which the assigned task is performed. They were written to reflect the critical performance standards for the competency.

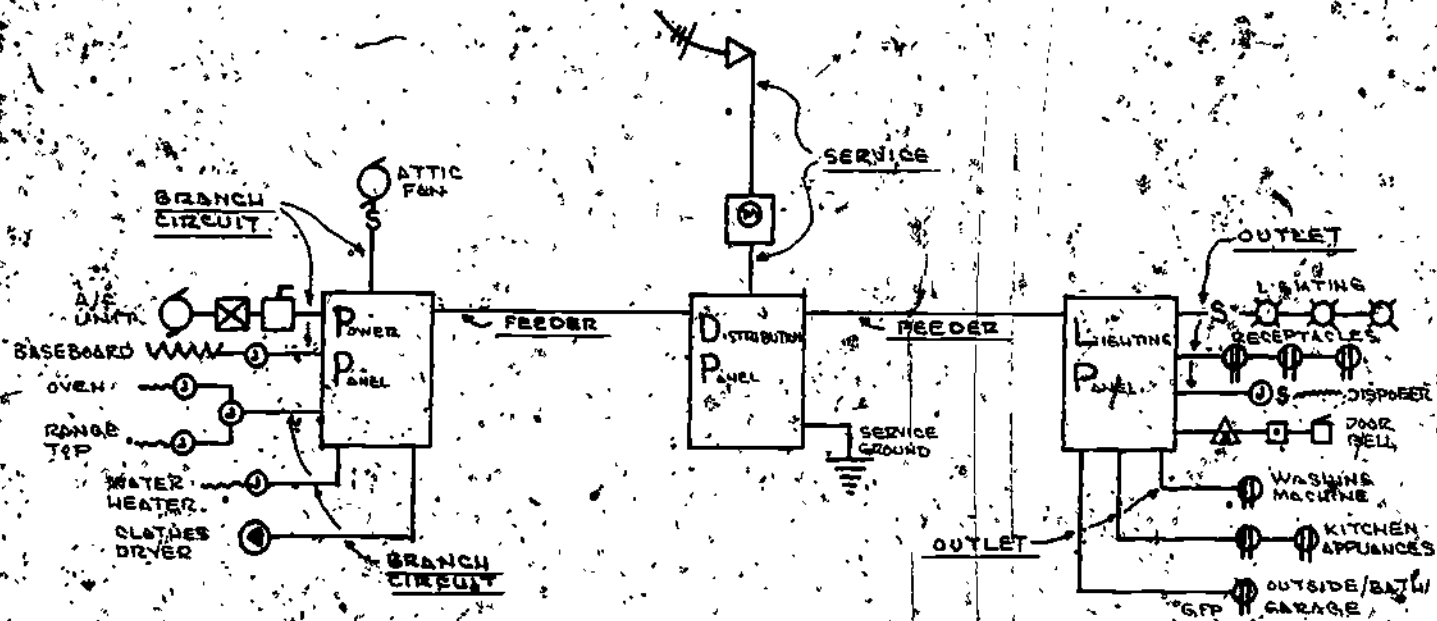

TYPICAL HOUSE RISER

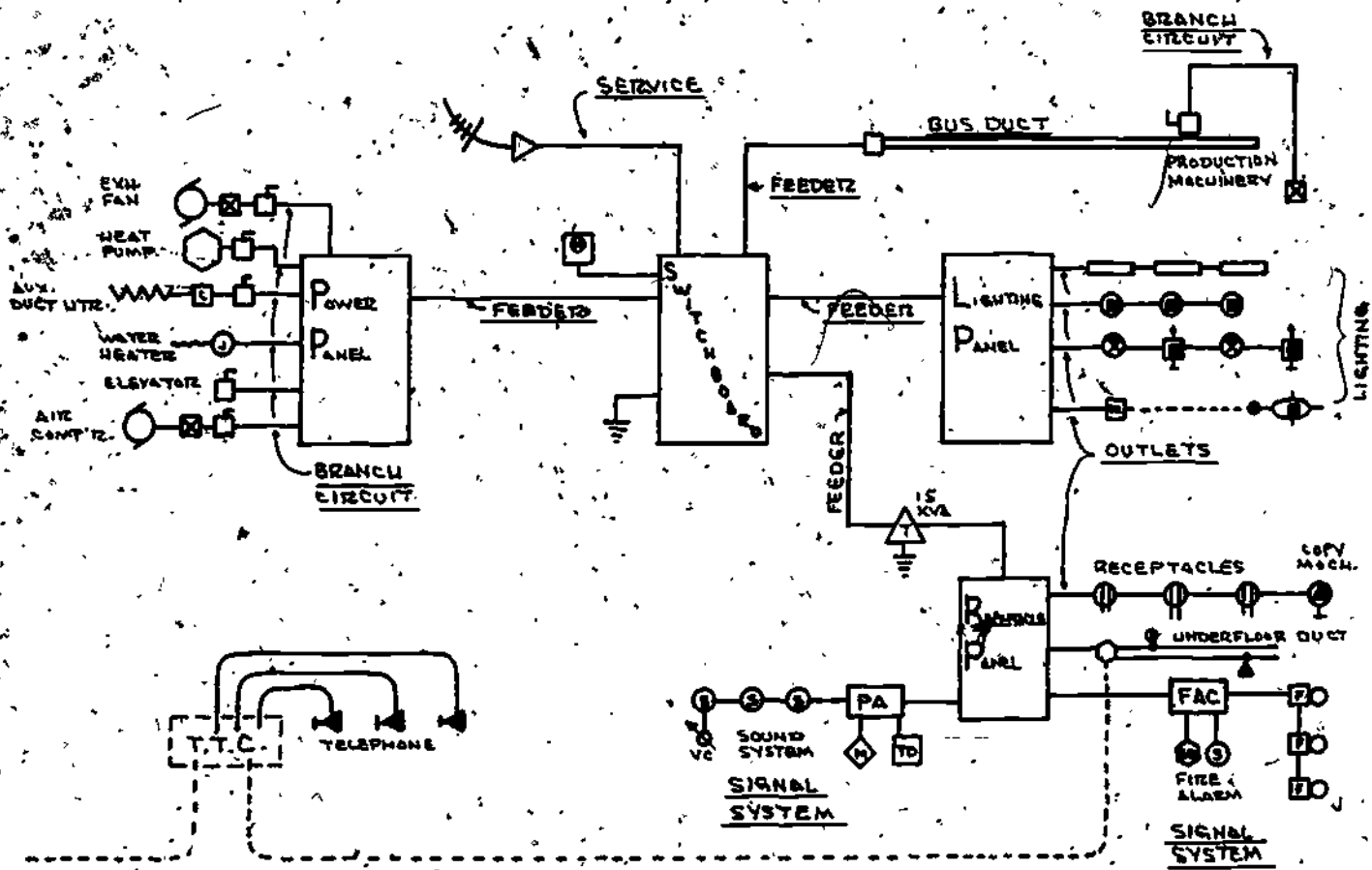

TYPICAL PLANT RISER

TASK AREA: Service Entrances

TASK A-11: Install service using metallic conduit and wire.

SUB-TASKS:

1. Locate service attachment point on building.
2. Route conduit from attachment point to service entrance equipment.
3. Measure, cut, thread (where necessary) and ream conduit and make bends and offsets as necessary to fit the building structure. (Locate position of hole with plumb bob for conduit to go through roof if service conduit is overhead.)
4. Fasten conduit to building structure and plumb.
5. Install weatherhead on conduit. (Install fitting for underground service if required.)
6. Install conduit terminals - locknuts and bushings - at meter box and at service entrance equipment.
7. Select, measure, cut, and mark identify phase and neutral conductor.
8. Pull conductors into conduit including any bonding conductors if necessary.
9. Install proper grounding.
 - a. Install the proper fittings within the meter box and within the service entrance equipment.
 - b. Mark and identify the grounding electrode conductor.
 - c. Install the properly sized grounding electrode conductor.
 - d. Connect the grounding conductor to the grounding fittings and to an approved grounding electrode system.
10. Connect proper conductor to the proper terminal.
11. Re-seal insulation envelope penetrations to maintain energy efficiency.

COMPETENCY: Install service entrance conduit from weatherhead, through meter box, into service entrance equipment to comply with governing codes, ordinances, plans and specifications.

12/13 18

CRITERION:

Can read and interpret plans and specifications to locate service entrance.

Can select correct service entrance equipment and cable to comply with codes, plans and specifications.

Can mount equipment and install wiring to comply with codes and ordinances.

Can make service entrance connections for an overhead service, an underground service and a service drop.

Can ground interior AC systems and bond all service entrance equipment according to the requirements of the National Electrical Code.

Can determine the size of service entrance conductors including the size of the neutral conductor for the most efficient and economic service.

Can apply various National Electrical Code regulations for the appropriate installation of service entrances and equipment for indoor, outdoor or underground routing.

TASK AREA: Service Entrances

TASK A-12: Install service using non-metallic service entrance cable.

SUB-TASKS:

1. Locate service attachment point on building.
2. Measure, cut, and route cable from attachment point to service entrance equipment.
3. Mark and identify phase and neutral conductors.
4. Fasten weatherhead, meter box and cable to building structure.
5. Install weatherhead on cable.
6. Install proper grounding electrode.
 - a. Install proper grounding fittings within the meter box and within the service entrance equipment.
 - b. Mark and identify the grounding electrode conductor.
 - c. Install the properly sized grounding electrode conductor.
 - d. Connect the grounding conductor to the grounding fittings and to an approved grounding electrode system.
7. Connect proper cable conductor to the proper terminal.
8. Re-seal insulation envelope penetrations to maintain energy efficiency.

COMPETENCY: Install service entrance cable from weatherhead, through meter box, into service entrance equipment to comply with governing codes, ordinances, plans and specifications.

CRITERION: Can read and interpret plans and specifications to locate service entrance.

Can select correct service entrance equipment and cable to comply with codes, plans and specifications.

Can mount equipment and install wiring to comply with codes and ordinances.

Can make service entrance connections for an overhead service, an underground service and a service drop.

Can ground interior AC systems and bond all service entrance equipment according to the requirements of the National Electrical Code.

Can determine the size of service entrance conductors including the size of the neutral conductor for the most efficient and economic service.

Can apply various National Electrical Code regulations for the appropriate installation of service entrances and equipment.

TASK AREA: Service Entrances

TASK A-13: Install service using non-metallic conduit and wire.

SUB-TASKS:

1. Locate service attachment point on building.
2. Route conduit from attachment point to service entrance equipment.
3. Measure, cut, thread (when necessary) and ream non-metallic conduit and make bends and offsets as necessary to fit the building structure.
4. Use solvent cement or weld couplings and connectors to form a complete raceway system.
5. Fasten conduit to building structure and plumb.
6. Install weatherhead on conduit.
7. Install conduit terminals - locknuts and bushings - at meter box and at service entrance equipment.
8. Select, measure, cut, and mark and identify phase and neutral conductors.
9. Pull conductors into conduit.
10. Install proper grounding.
 - a. Install proper grounding fittings within the meter box and within the service entrance equipment.
 - b. Install the properly sized grounding conductor.
 - c. Connect the grounding conductor to the grounding fittings and to an approved grounding electrode.
 - d. Mark and identify the grounding conductor.
11. Connect proper conductor to the proper terminal.
12. Re-seal insulation envelope penetrations to maintain energy efficiency.

COMPETENCY: Install service entrance conduit from weatherhead, through meter box, into service entrance equipment to comply with governing codes, ordinances, plans and specifications.

CRITERION: Can read and interpret plans and specifications to locate service entrance.

Can select correct service entrance equipment and cable to comply with codes, plans and specifications.

Can mount equipment and install wiring to comply with codes and ordinances.

Can make service entrance connections for an overhead service, an underground service and a service drop.

Can ground interior AC systems and bond all service entrance equipment according to the requirements of the National Electrical Code.

Can determine the size of service entrance conductors including the size of the neutral conductor for the most efficient and economic service.

Can apply various National Electrical Code regulations for the appropriate installation of service entrances and equipment for indoor, outdoor or underground routing.

TASK AREA: Feeders

TASK B-14: Install feeders using metallic conduit and wire.

SUB-TASKS:

1. Locate conduit route from service entrance equipment to branch circuit panel.
2. Measure, cut, thread (when necessary) and ream conduit and make bends and offsets as necessary to fit the building structure.
3. Fasten conduit to building structure.
4. Install conduit terminals - locknuts and bushings - at ends of conduit runs.
5. Select, measure, cut, and mark and identify phase and neutral conductors.
6. Pull conductors into conduit.
7. Connect proper conductor to the proper terminal.
8. Re-seal insulation penetrations to maintain energy efficiency.

COMPETENCY: Install feeder conduits from service entrance equipment to branch circuit panels, to comply with governing codes, ordinances, plans and specifications.

CRITERION: Can read and interpret plans and specifications to locate route and size of feeder conductors and conduit.

Can select the proper feeder conductor type and size to comply with codes, plans and specifications.

Can install the conduit with the proper terminators for either indoor, outdoor or underground routing to comply with codes, plans and specifications.

Can install the conductors in the conduit to comply with codes, plans and specifications.

Can mark and identify each conductor according to the requirements of the National Electrical Code.

TASK AREA: Feeders

TASK B-15: Install feeders using non-metallic conduit and wire.

SUB-TASKS:

1. Locate conduit route from service entrance equipment to branch circuit panel.
2. Measure, cut, thread and ream non-metallic conduit and make bends and offsets as necessary to fit building structure.
3. Use solvent cement or weld couplings and connectors to form a complete raceway system.
4. Fasten conduit to building structure.
5. Install conduit terminals - locknuts and bushings - at ends of conduit runs.
6. Select, measure, cut, and mark and identify phase and neutral conductors.
7. Pull conductor, including equipment grounding conductors into conduit.
8. Connect proper conductor to the proper terminal.
9. Re-seal insulation penetrations to maintain energy efficiency.
10. Install equipment grounding conductor in sub-panel.

COMPETENCY: Install feeder conduits from service entrance equipment to branch circuit panels, to comply with governing codes, ordinances, plans and specifications.

CRITERION: Can read and interpret plans and specifications to locate route and size of feeder conductors and conduit.

Can select the proper feeder conductor type and size to comply with codes, plans and specifications.

Can install the conduit with the proper terminators for either indoor, outdoor or underground routing to comply with codes, plans and specifications.

Can install the conductors in the conduit to comply with codes, plans and specifications.

Can mark and identify each conductor according to the requirements of the National Electrical Code.

TASK AREA: Feeders

TASK B-16: Install feeders using non-metallic cable.

SUB-TASKS:

1. Locate route for cable from service entrance equipment to branch circuit panel.
2. Mark and identify phase and neutral conductors and grounding conductor, where required.
3. Fasten cable to building structure.
4. Install cable connectors where cable enters panel or box.
5. Connect proper cable conductor to the proper terminal.
6. Re-seal insulation envelope penetrations to maintain energy efficiency.
7. Install equipment grounding bar in sub-panel.

COMPETENCY: Install feeder cables from service entrance equipment to branch circuit panels to comply with governing codes, ordinances, plans and specifications.

CRITERION: Can read and interpret plans and specifications to locate route and size of feeder cables.

Can select correct size feeder cables and connectors to comply with codes, plans and specifications.

Can install feeder cables and connectors to comply with codes, plans and specifications for indoor, outdoor or underground routing.

Can ground feeder cables according to the requirements of the National Electrical Code.

Can mark and identify each conductor according to the requirements of the National Electrical Code.

TASK AREA: Panelboards and Switchboards

TASK C-17: Install panelboards and switchboards.

SUB-TASKS:

1. Identify location of panelboard or switchboard within building.
2. Mount panel box to building structure or set on floor and level as required by manufacturer, specifications and governing codes.
3. Install interiors - bussing and overcurrent protective devices.
4. Connect neutral and/or equipment grounding wires to their proper busses.
5. Connect feeder or branch circuit wires to the load-side of overcurrent.
6. Connect incoming panel or switchboard feeder wires to main bussing.
7. Fill in circuit directory card or individual circuit labels.
8. Install trim and cover.

COMPETENCY: Install panelboards and switchboards, connect branch circuits and feeders according to panel and switchboard schedules, governing codes, ordinances, plans and specifications.

CRITERION: Can determine location of panelboard or switchboard according to codes, plans and specifications.

Can mount or set panelboard or switchboard according to codes and specifications.

Can install interior and connect branch circuits and feeders according to schedules, codes and specifications.

Can test to assure that circuits are properly installed.

Can install the correct fuse types according to the requirements of the National Electrical Code including the following: plug, cartridge, dual element, knife, slow blow, and renewable fuses.

Can install the correct circuit breaker according to the requirements of the National Electrical Code including the following: G.F.I. and current limiting circuit breaker.

Can select both fuses and circuit breakers for specific applications according to the requirements of the National Electrical Code.

Can locate short circuits and open circuits using appropriate tools and test instruments.

Can locate, lock open and tag power cut-off, both building main and individual circuits.

Can determine wire and panel size for a main panel and load center according to the requirements of the National Electrical Code.

TASK AREA: Duct Systems

TASK D-18: Install bus duct systems.

SUB-TASKS:

1. Locate bus duct runs and install hangers.
2. Fasten duct to hangers and to its adjacent section until complete and plumb.
3. Connect line-side cables or make bus connections as required.
4. Install plug-in overcurrent protective devices where applicable.
5. Plumb and level completed installation.

COMPETENCY: Install bus ducts as required to meet job specifications. This may include service bus duct, feeder bus duct or plug-in bus duct serving a number of branch circuits. Installation is to comply to the governing codes and ordinances, plans and specifications.

CRITERION: Can locate and install bus ducts in their hangers to meet job plans and specifications and manufacturer's instructions.

Can properly assemble the various parts to make a complete, functional system, according to plans, specifications, codes, ordinances and manufacturer's instructions.

Can properly connect the feeder and grounding conductors to their proper terminals.

Can select and install the correct bus plug overcurrent protective device to serve the individual branch circuits shown on the plans.

TASK AREA: Duct Systems

TASK D-19: Install underfloor duct system.

SUB-TASKS:

1. Locate underfloor duct system layout within the building.
2. Position and orient junction/pull boxes in their proper places.
3. Lay duct runs in support saddles and fasten in position.
4. Make final adjustments before and corrections during concrete pour.
5. Locate floor service fittings.
6. Pull in conductors and/or cables from serving locations to floor service fittings and make connections.

COMPETENCY: Install underfloor duct system to serve power, communication and signal devices as required by the job specifications and plans to comply with governing codes and ordinances.

CRITERION: Can locate, lay out and position the underfloor duct system according to plans and specifications, codes and ordinances.

Can connect duct runs to junction boxes and to panels and serving equipment (telephone terminal cabinets and signal cabinets).

Can install floor service fittings and make proper connections to the serving conductors and cables.

TASK AREA: Grounding

TASK E-20: Ground non-metallic conduit raceway systems.

SUB-TASKS:

1. Install properly sized grounding conductor according to job plans.
2. Mark and identify the grounding conductor.
3. Connect grounding conductor to the ground bus and to the proper grounding terminal.

COMPETENCY: Install and connect grounding conductor for services, feeders, branches and special systems served by non-metallic conduit and wire to comply with governing codes, ordinances, plans and specifications.

CRITERION: Can size and install the proper grounding conductors for the following according to National Electrical Code requirements.

1. Service conduits.
2. Feeder conduits.
3. Branch circuit conduits.
4. Special systems conduits.

Can select and install the proper equipment to comply with codes, ordinances, plans and specifications.

TASK AREA: Grounding

TASK E-21: Ground devices, fixtures and equipment.

SUB-TASKS:

1. Mark and identify the grounding conductor.
2. Install the properly sized grounding conductor from the branch circuit grounding conductor or raceway to the grounding terminal on the device, fixture or to the housing of the equipment being served.

COMPETENCY: Connect grounding conductor to the proper grounding terminal of the devices or equipment housing to comply with governing codes, ordinances, plans and specifications.

CRITERION: Can size and install the proper grounding conductor from the serving branch circuit to the outlet box and to the grounding terminal of the device.

Can size and install the proper grounding conductor from the serving branch circuit to the outlet box and fixture housing or channel.

Can size and install the proper grounding conductor from the serving branch circuit to the equipment enclosure.

Can select and install the proper equipment to comply with codes, ordinances, plans and specifications.

TASK AREA: Grounding.

TASK E-22: Ground transformers

SUB-TASKS:

1. Mark and identify the grounding conductor.
2. Install properly sized grounding conductor from case of transformer to the equipment grounding conductor and to the building steel.
3. Install properly sized grounding conductor from the neutral point on the transformer to the equipment grounding conductor where required.

COMPETENCY: Install grounding conductor for transformer case and/or neutral point ground to comply with governing codes, ordinances, plans and specifications.

CRITERION: Can size and install proper grounding conductor for the transformer case according to National Electrical Code requirements.

Can select and install the proper equipment to comply with codes, ordinances, plans and specifications.

TASK AREA: Branch Circuits

TASK F-23: Install branch circuit using metallic conduit and wire.

SUB-TASKS:

1. Locate conduit route within building.
2. Locate and size pull boxes (junction boxes).
3. Route conduit from panel to equipment being served.
4. Measure, cut, thread and ream conduit and make bends and offsets as necessary to fit the building structure.
5. Fasten conduit to building structure.
6. Mount boxes and additional fixture support as required at proper height and location for intended use.
7. Install conduit terminals - locknuts and bushings - at ends of conduit run.
8. Select, measure, cut, and mark and identify phase and neutral conductors.
9. Pull conductors into conduit.
10. Fold conductors into box or connect to the proper terminal of the equipment being served.
11. Re-seal insulation envelope penetrations to maintain energy efficiency.

COMPETENCY: Install branch circuit conduit and wire from panel over-current protective device to equipment being served to comply with governing codes, ordinances, plans and specifications.

CRITERION: Can install split circuits for convenience receptacles including the balancing of neutral and the termination of conductors.

Can determine load requirements and install multi-outlet assemblies.

Can install outlets and receptacles in wet and damp locations according to the requirements of the National Electrical Code.

Can install attic wiring that meets the National Electrical Code requirements.

Can select the proper wiring method (cable or conduit) for a garage and complete the wiring installation.

Can install conduit in concrete floors underground and on block walls according to the requirements of the National Electrical Code.

Can select the proper sizes of receptacle boxes and install.

Can apply the proper ampacity derating factors to conductors according to the requirements of the National Electrical Code.

Can recognize the need for and can calculate the necessary load requirements for special outlets.

Can make the proper grounding connections according to the requirements of the National Electrical Code.

Can make connections to insure grounding continuity between an outlet box and the grounding circuit conductor of a receptacle.

Can select wire with appropriate thermal insulation for special wiring requirements.

TASK AREA: Branch Circuits

TASK F-24: Install branch circuit using non-metallic conduit and wire.

SUB-TASKS:

1. Locate conduit route within building.
2. Locate and size pull boxes (junction boxes).
3. Route conduit from panel to equipment being served.
4. Measure, cut and ream non-metallic conduit and make bends and offsets as necessary to fit building structure.
5. Use solvent cement or weld couplings and connectors to form a complete raceway system.
6. Mount boxes and additional fixture support as required at proper height and location for intended use.
7. Fasten conduit to building structure.
8. Install conduit terminals - locknuts and bushings - at ends of conduit run.
9. Select, measure, cut, and mark and identify phase and neutral conductors.
10. Pull conductors into conduit.
11. Fold conductors into box or connect to the proper terminal of the equipment being served.
12. Re-seal insulation envelope penetrations to maintain energy efficiency.

COMPETENCY: Install branch circuit conduit and wire from panel over-current protective device to equipment being served to comply with governing codes, ordinances, plans and specifications.

CRITERION: Can install split circuits for convenience receptacles including the balancing of neutral and the termination of conductors.

Can determine load requirements and install multi-outlet assemblies.

Can install outlets and receptacles in wet and damp locations according to the requirements of the National Electrical Code.

Can install attic wiring that meets the National Electrical Code requirements.

Can select the proper wiring method (cable or conduit) for a garage and complete the wiring installation.

Can install conduit in concrete floors underground and on block walls according to requirements of the National Electrical Code.

Can select the proper sizes of receptacle boxes and install.

Can apply the proper ampacity derating factors to conductors according to the requirements of the National Electrical Code.

Can recognize the need for and can calculate the necessary load requirements for special outlets.

Can make the proper grounding connections according to the requirements of the National Electrical Code.

Can make connections to insure grounding continuity between an outlet box and the grounding circuit conductor of a receptacle.

Can select wire with appropriate thermal insulation for special wiring requirements.

TASK AREA: Branch Circuits

TASK F-25: Install branch circuit using non-metallic cable.

SUB-TASKS:

1. Mount boxes and additional fixture support as required at proper height and location (to meet National Electrical Code requirements) for intended use.
2. Locate cable route within building and drill or notch studs.
3. Fasten cable to building structure.
4. Install cable connectors at ends of cable at each box installed.
5. Mark and identify phase and neutral and grounding conductors when required.
6. Fold conductors into box.
7. Re-seal insulation envelope penetrations to maintain energy efficiency.

COMPETENCY: Install branch circuit cable from panel overcurrent protective device to equipment being served to comply with governing codes, ordinances, plans and specifications.

CRITERION: Can install split circuits for convenience receptacles including the balancing of neutral and the termination of conductors.

Can determine load requirements and install multi-outlet assemblies.

Can install outlets and receptacles in wet and damp locations according to the requirements of the National Electrical Code.

Can install attic wiring that meets the National Electrical Code.

Can select the proper wiring method (cable or conduit) for a garage and complete the wiring installation.

Can apply the proper ampacity derating factors to conductors according to the requirements of the National Electrical Code.

Can recognize the need for and can calculate the necessary load requirements for special outlets.

Can make the proper grounding connections according to the requirements of the National Electrical Code.

Can make connections to insure grounding continuity between an outlet box and the grounding circuit conductor of a receptacle.

Can select the proper sizes of receptacle boxes and install.

Can select wire with appropriate thermal insulation for special wiring requirements.

TASK AREA: Branch Circuits

TASK F-26: Install local control switches and plates.

SUB-TASKS:

1. Select the proper switch for each specific location shown on the drawings.
2. Unfold conductors left in outlet box and strip insulation from ends.
3. Make required equipment grounding conductor connections.
4. Connect proper conductor to its terminal on the switch:
 - a. Single pole switch
 - b. Double pole switch
 - c. Three-way switch
 - d. Four-way switch
 - e. Combination switch and pilot light
5. Mount device onto outlet box in its proper position.
6. Install switch plate.

COMPETENCY: Install local control switches and plates according to plans and specifications to comply with governing codes and ordinances.

CRITERION: Can connect dimmer for incandescent and fluorescent lamp circuits according to National Electrical Code requirements, and manufacturer's instructions.

Can install a pilot light switch according to the requirements of the National Electrical Code.

Can connect the following types of switches:

1. Three-way and four-way
2. Single pole single throw
3. Single pole double throw
4. Double pole double throw
5. Rotary single and multiple position
6. Push button
7. Photo-electric

Can select and install appropriate control devices for specific applications.

Can complete the wiring of a low voltage control circuit.

TASK AREA: Branch Circuits

TASK F-27: Install receptacles and plates.

SUB-TASKS:

1. Select the proper receptacle or special purpose outlet for each specific location shown on the drawing.
2. Unfold conductors left in outlet box and strip insulation from ends.
3. Make required equipment grounding conductor connections.
4. Connect proper conductor to its terminal on the device:
 - a. General purpose receptacles
 - b. Appliance receptacles
 - c. Cord connected equipment
 - d. Special purpose receptacles.
5. Mount receptacle onto outlet box in its proper position.
6. Install receptacle plate.

COMPETENCY: Install and connect receptacles, special purpose outlets and plates according to plans and specifications to comply with governing codes and ordinances.

CRITERION: Can connect general purpose and special receptacles as required by the National Electrical Code.

Can install and connect G.F.I. (Ground Fault Interrupter) receptacles according to manufacturer's instructions and the National Electrical Code.

Can install receptacles in wet or damp locations, utilizing the proper equipment for the encountered environment.

Can install split circuit receptacles and can properly balance neutral conductors on these circuits.

Can determine load requirements for general purpose and special receptacles as required by the National Electrical Code.

TASK AREA: Branch Circuits

TASK F-28: Install fixtures and lamps.

SUB-TASKS:

1. Select proper fixture for each specific location shown on the drawings.
2. Unpack, disassemble as needed to mount and make wiring connections.
3. Install mounting hardware and additional fixture support as needed.
4. Connect fixture leads to proper conductors including grounding conductors in outlet box. (Flexible conduit may be required if fixture is to be removable for servicing.)
5. Mount and reassemble fixture and install lamps.
6. Close up fixture.

COMPETENCY: Install fixtures and lamps according to job plans and specifications to comply with codes and ordinances.

CRITERION: Can properly connect a fixture lamp socket to the proper circuit conductor.

Can properly connect fluorescent and high intensity discharge fixture ballasts.

Can properly mount and secure fixture housing to outlet boxes, ceiling support systems or building structure as required by the National Electrical Code.

Can select the proper temperature-rated wire to make final fixture connections when required by the National Electrical Code.

Can determine the circuit load allowed for continuous duty lighting as required by the National Electrical Code.

46/47

42

TASK AREA: Branch Circuits

TASK F-29: Install outside lighting

SUB-TASKS:

1. Locate individual positions where lighting equipment is to be installed.
2. Extend branch circuits to each established location:
 - a. Ditching.
 - b. Install into concrete base and waterproofing conduits
 - c. Direct burial cable
 - d. Sleeves under roads
3. Form bases, install conduit and pour concrete bases where required.
4. Set poles and install fixtures.
5. Connect pole ground to metallic raceway grounding fitting or to equipment grounding conductor.
6. Connect proper conductor to the proper fixture terminal.
7. Install lamp and close fixture.

COMPETENCY: Install outside lighting as required by job plans and specifications to comply with governing codes and ordinances.

CRITERION: Can interpret plans and specifications to physically locate circuit routing and base positions.

Can select and properly install pole grounding to comply with National Electrical Code requirements for the environment in which they are installed.

Can lay out base forms, anchor bolts and reinforcing where required to accurately construct a poured-in-place concrete base.

Can properly set and secure poles to bases and ground poles.

Can properly install fixtures on poles and connect serving branch circuit conductors to their proper terminals.

4/8/49

43

TASK AREA: Low Voltage Control Systems

TASK G-30: Install low voltage control system.

SUB-TASKS:

1. Locate individual outlets to be controlled within the building.
2. Select central location and install relay cabinet.
3. Select proper size relay for load circuit.
4. Install local control switches and master.
5. Route control cable from switches to relay cabinet and from individual outlets to be controlled to relay cabinet.
6. Make interconnections as required and connect power supply.
7. Re-seal insulation envelope penetrations to maintain energy efficiency.

COMPETENCY: Install low voltage control system to comply with governing codes, ordinances, plans and specifications.

CRITERION: Can locate and properly install local control devices and the master controller according to plans and manufacturer's instructions.

Can locate and properly install the control relay panel.

Can select, install and properly fasten the control cable from local control devices to relay control panels, master controller and relay control panel and other control positions as required by plans and manufacturer's instructions.

Can properly connect external power conductors and/or signal conductors as specified.

TASK AREA: Signal Systems

TASK H-31: Install signal systems.

SUB-TASKS:

1. Locate central control for each system within the building premises.
2. Extend conduits, conductors and/or cables to remote station devices.
3. Mount and connect the proper conductor to its identified terminal on the installed remote station device.
4. Install incoming power and/or signal conductors and connect.
5. Test and have certification of proper authorities made as to equipment operation.

COMPETENCY: Install telephone, sound, fire alarm, building security, closed circuit television or other systems according to job specifications and plans to comply with governing codes and ordinances.

CRITERION: Can locate and install the central controller for each signal system according to plans and specifications. These systems include, but are not necessarily limited to:

1. Fire alarm
2. Telephone
3. Sound (music or paging)
4. Energy management
5. Building security
6. Closed circuit television
7. Data process

Can locate and install the individual remote station devices for each signal system according to plans and specifications.

Can properly install and connect the conductor and/or cables to interconnect the remote station devices with the corresponding central controller according to plans and specifications, codes, ordinances and manufacturer's instructions. These remote devices include telephone outlets, alarm break glass stations, horns, bells, speakers, microphones, amplifiers, tuners, tape decks, door switches, motion and infrared detectors, television cameras, monitors, remote data process terminals, temperature and pressure switches, smoke detectors, and remote energy management control devices.

Can properly install and connect the serving power to
the equipment and its resultant output signal to its
proper intended use.

S

TASK AREA: Transformers

TASK I-32: Install transformers

SUB-TASKS:

1. Locate installation position of transformer.
2. Locate a suitable secondary grounding point if necessary.
3. Mount transformer and insure overcurrent protection.
4. Connect properly sized line, load, neutral, and grounding conductors to proper terminals.
5. Check to determine proper voltage is being obtained.

COMPETENCY: Install and connect transformer to produce specified voltage to comply with governing codes, ordinances, plans and specifications, and manufacturer's instructions.

CRITERION: Can connect both step-up and step-down transformers in a circuit.

Can interpret transformer wiring diagrams necessary and make the following connections: wye-wye, wye-delta, delta-delta, and delta-wye.

Can connect transformers in single phase three wire, three phase three wire, and three phase four wire circuits.

Can identify and mark neutral (as related to earth) in a single phase three wire system.

Can connect both a wye and delta polyphase four wire system transformer.

TASK AREA: Electric Heating

TASK J-33: Install electric heaters

SUB-TASKS:

1. Locate each heater position within the building.
2. Calculate load, where required, for overcurrent, protective device, correctly sized branch circuit and equipment grounding conductor, and correctly sized disconnect.
3. Calculate load, mount heater, controller and disconnect where required.
4. Connect proper branch circuit conductor to the proper heater, controller or disconnect terminal.
5. Make grounding connections.
6. Mount, wire and connect temperature controller as required.

COMPETENCY: Install and connect electric resistance heaters to comply with governing codes and ordinances, plans and specifications.

CRITERION: Can install electric heaters with appropriate contactors and/or temperature controls according to the requirements of the National Electrical Code.

TASK AREA: Electric Heating

TASK J-34: Install electric heat cables and mats.

SUB-TASKS:

1. Calculate load where required for overcurrent protective device, correctly sized branch circuit and equipment grounding conductor, and correctly sized disconnect.
2. Locate and lay out cable and mat runs in their proper position within the premises.
3. Avoid obstructions which would damage or short cables or mats. Fasten in position.
4. Test for continuity and grounded heat cable or mat.
5. Extend cold leads to branch circuit outlet and connect proper lead to the proper branch conductor.
6. Seal outlet hubs if subject to moisture.
7. Install and properly connect controllers and disconnects.

COMPETENCY: Install electric heat cable and mats to comply with governing codes, ordinances, plans and specifications.

CRITERION: Can install various electrical heat cable and mats in correct pattern and spacing according to National Electrical Code requirements.

Can install various thermostat control systems for electric heating units.

58/59 49

TASK AREA: Motors and Controls

TASK K-35: Make motor load calculations for single and three phase AC motors, DC motors.

SUB-TASKS:

1. Identify motor voltage, phases, full load current, frequency, time (duty cycle) rating, temperature rise or insulation class, horsepower rating, code letter, secondary volts and full-load amperes if wound rotor induction motor, field current and voltage for DC excited synchronous motors, type winding: straight shunt, stabilized shunt, compound or series if a DC motor, and indications of thermal or impedance protection.
2. Apply necessary data to the specific application at hand.
3. Make the required mathematical calculations.
4. Select and size motor circuit overcurrent protective device.
5. Select motor circuit conductor size and insulation type.
6. Select motor controller, size and type:
 - a. Full voltage
 - b. Reduced voltage
 - c. Manual
 - d. Automatic
 - e. Reversing
 - f. DC
7. Select and size overload protective device.
8. Select and size thermal protective device.
9. Select and size fault current protective device.
10. Select and size motor disconnect means.
11. Select and size motor grounding means.

COMPETENCY: Make motor load calculations for single and three phase AC motors and DC motors to comply with governing codes, ordinances, plans and specifications. Apply the results of these calculations to determine:

1. Motor circuit overcurrent protection
2. Circuit conductor size
3. Controller size
4. Overload protection
5. Thermal protection
6. Fault current protection
7. Disconnect means
8. Grounding means

60/61

50

CRITERION: Can identify unusual as well as standard motor markings on their nameplates or as specified.

Can properly apply this data to correctly calculate:

1. Motor circuit overcurrent protection
2. Motor circuit conductor size and insulation
3. Motor controller size and type
4. Motor overload protection
5. Motor thermal protection
6. Motor fault current protection
7. Motor disconnect means
8. Motor grounding means

51

TASK AREA: Motors and Controls

TASK K-36: Install starters, controllers, disconnects and individual overcurrent devices.

SUB-TASKS:

1. Calculate load.
2. Locate individual positions where starters, controllers, disconnects and individual overcurrent protective devices are required for the job.
3. Select the proper item of equipment for the intended location and mount. Connect the proper line and load-side conductors to their proper terminals.
4. Install proper coil and overload relays for starters and/or controllers.
5. Install the proper fuse, motor circuit protector or circuit breaker.
6. Connect auxillary relays and contacts to their proper terminals for remote operation and load management control functions.
7. Test for proper sequence or control function.

COMPETENCY: Install starters, controllers, disconnect switches and individual overcurrent protective devices as required by job specifications and plans to comply with governing codes and ordinances.

CRITERION: Can read and interpret plans and specifications to select and locate the correct equipment for the required equipment control.

Can mount equipment and install wiring to comply with codes and ordinances.

Can determine load requirements and install properly sized fuses, circuit breaker, motor circuit protectors and overload relays.

Can properly connect control circuits to obtain correct equipment operation.

TASK AREA: Motors and Controls

TASK K-37: Install motors.

SUB-TASKS:

1. Verify sizing of motor for mechanical load served.
2. Locate motor and its serving branch circuit.
3. Extend branch circuit into motor terminal housing.
(Flexible conduit may be required.)
4. Connect proper branch circuit conductor and grounding conductor to the proper motor terminal lead and motor housing (cat head) and insulate. This includes single and three phase motors with one or more motor leads per line conductor, as well as dual-voltage and reduced voltage motors.
5. Test and verify for proper motor line voltage.
6. Verify proper rotation before attachment to mechanical load.
7. Connect load to motor.
8. Close motor terminal housing.

COMPETENCY: Install and connect single phase and three phase motors as required by job specifications and plans to comply with governing codes and ordinances.

CRITERION: Can make the connections necessary for the operation of single phase and three phase AC motors.

Can connect motor and motor controls according to diagrams detailed on a schematic.

64/53
65

TASK AREA: Motors and Controls

TASK K-38: Install relays, timing devices and other auxiliary pilot devices.

SUBTASKS:

1. Locate position of pilot device and controller.
2. Determine what it is to control.
3. Install control conductors between the pilot device and the controller.
4. Make proper connections at pilot devices and at the controller.
5. Make necessary travel limiting, pressure, flow or time and temperature adjustments as required.
6. Energize control circuit to check proper sequence of operation.

COMPETENCY: Install relays, timing devices, and auxiliary pilot devices to comply with governing codes and ordinances, plans and specifications.

CRITERION: Can locate the position of the pilot device.

Can determine what it is to control.

Can make the proper line conductor connections between the controller and the pilot device.

Can make proper limit operation adjustments as required.

Can identify, diagram and describe the following basic pilot devices:

- | | |
|--------------------|-------------------------|
| 1. Float switch | 6. Push button stations |
| 2. Pressure switch | 7. Plugging switches |
| 3. Limit switch | 8. Time clocks |
| 4. Flow switch | 9. Relays |
| 5. Thermostat | |

66/67 54

TASK AREA: Maintenance

TASK L-39 Perform maintenance on panelboards and switchboards.

SUB-TASKS:

1. Disconnect power source, lock-off and tag using appropriate equipment and following standard safety practices.
2. Remove covers, access panel doors, etc.
3. Inspect for electrical arc damage.
4. Clean panel and components with electrical solvent.
5. Clean, adjust and tighten all connections and joints to specified torque tightness.
6. Inspect switch contacts for wear and arc damage.
7. Inspect mechanical operation of each unit to be sure it works smoothly.
8. Check overcurrent protective devices for proper size, operation and function.
9. Secure covers and access doors.
10. Remove lock-off and tag and energize equipment.

COMPETENCY: Perform maintenance on panelboards and switchboards so they will function properly, accurately control current flow and provide overcurrent protection, according to manufacturer's instructions.

CRITERION: Can disconnect, lock-off and tag the power source.

Can clean, adjust and tighten all connections and joints and interior to specified torque tightness.

Can inspect wear points of switch units, and replace as required.

Can check performance of equipment for inefficient energy consumption during regular maintenance interval.

Can test overcurrent protective devices for proper function and operation.

Can secure equipment.

Can maintain equipment so that it will operate efficiently and therefore be energy conserving.

68/69

55

TASK AREA: Maintenance

TASK L-40: Perform maintenance of motor controllers and operator control switches.

SUB-TASKS:

1. Locate, disconnect, lock-off and tag power source to equipment using appropriate equipment and following standard safety practices.
2. Remove enclosure covers and inspect for electrical arc damage.
3. Clean, with electrical solvent cleaner, adjust and tighten all connections and joints.
4. Clean and adjust all moving parts for free operation.
5. Inspect wear points of relays, contacts and spring tensions - replace if necessary.
6. Inspect mechanical operation of each unit to be sure it works smoothly.
7. Secure equipment enclosure covers.
8. Remove lock-off and tag and energize equipment.

COMPETENCY: Check, service and adjust motor controllers and operator control switches to function properly according to manufacturer's instructions.

CRITERION: Can disconnect, lock-off and tag power source.

Can clean, adjust and tighten all connections and joints and interiors.

Can inspect wear points of relays and contacts and spring tensions, replace if necessary.

Can check performance of equipment for inefficient energy consumption during each regular maintenance interval.

Can secure equipment housing covers.

Can unlock and reconnect power source and remove safety lock-off tag.

Can install capacitors to improve power factor.

Can maintain equipment so that it operates efficiently and therefore is energy conserving.

70/71

TASK AREA: Maintenance

TASK L-41: Perform maintenance on single phase and three phase motors.

SUB-TASKS:

1. Locate, disconnect, lock-off and tag power source using appropriate equipment and following standard safety practices.
2. Remove motor terminal housing cover and mark end bells and remove.
3. Inspect and tighten terminal connections - close terminal housing cover.
4. Inspect bearings, couplings, shaft alignment and play, centrifugal switches, stator and rotor condition and balance.
5. Apply lubrication to points as recommended by manufacturer.
6. Repair or replace any defective parts.
7. Clean housing interior and confirm proper equipment ventilation.
8. Put end bells and covers back on and secure.
9. Assemble, mount, adjust and tighten to manufacturer's specifications.
10. Remove lock-off and tag and reconnect power.
11. Check for efficient and proper motor operation.

COMPETENCY: Check, service and adjust motor to properly drive its load, according to manufacturer's instructions.

CRITERION: Can disconnect, lock-off and tag power source.

Can inspect terminal connections, bearings, couplings, ventilation, shaft alignment and play, centrifugal switches, stator and rotor condition and balance.

Can check performance of equipment for inefficient energy consumption during each regular maintenance interval.

Can replace or repair defective items.

Can secure equipment housing covers.

Can unlock and reconnect power source and remove safety lock-off tag.

Can install capacitors to improve power factor.

72/73

57

Can size equipment properly for specific job so that it will be energy efficient, not oversized or undersized.

Can maintain equipment so that it operates efficiently and therefore is energy conserving.

TASK AREA: Maintenance

TASK L-42: Perform maintenance on transformers - single phase and three phase.

SUB-TASKS:

1. Locate, disconnect, lock-off and tag power source using appropriate equipment and following standard safety practices.
2. Remove transformer access doors and inspect for overheating and arc damage.
3. Check all terminals for feedback voltage before attempting any service.
4. Clean and tighten all joints to specified torque tightness.
5. Check oil filled transformers for level, oil leaks and take oil sample for moisture check.
6. Check for cracked insulators and clean.
7. Clean dust from interior of case and ventilation openings.
8. Put access doors and covers back in place and secure.
9. Remove lock-off and tag and reconnect power source.
10. Check and record operating temperature and sound level.

COMPETENCY: Check, service and adjust single phase and three phase transformers to function properly, according to manufacturer's instructions.

CRITERION: Can disconnect, lock-off and tag power source.

Can clean and tighten all connections and joints and interior.

Can inspect insulation for overheating and deterioration.

Can check performance of equipment for inefficient energy consumption during each regular maintenance interval.

Can secure equipment housing covers.

Can unlock and reconnect power source and remove safety lock-off tag.

Can inspect operating temperature and sound level.

Can size equipment properly for specific job so that it will be energy efficient, not oversized or undersized.

Can maintain equipment so that it will operate efficiently and therefore be energy conserving.

60

76

TASK AREA: Maintenance

TASK L-43: Perform maintenance on load management controllers.

SUB-TASKS:

1. Locate, disconnect, lock-off and tag power source using appropriate equipment and following standard safety practices.
2. Remove covers and equipment housings.
3. Clean, with electrical solvent cleaner, adjust and tighten all connections and joints.
4. Inspect contacts for arc damage, replace if necessary.
5. Check movable parts for free and smooth operation.
6. Check coils for overheating.
7. Re-install covers and equipment housings.
8. Remove lock-off and tag and reconnect power source.
9. Observe several operational cycles to be sure system is operating properly.

COMPETENCY: Check, service and adjust the various parts and pieces of the load management control system for proper function and operation for energy efficient operation.

CRITERION: Can disconnect and lock-off and tag power source.

Can clean, adjust and tighten all connections and joints and interiors.

Can inspect wear points of controllers and relays, replace if necessary.

TASK AREA: Maintenance

TASK L-44: Perform maintenance on grounding systems.

SUB-TASKS:

1. Lock-off power.
2. Locate each grounding point of building grounding system.
3. Inspect for electrical arc damage.
4. Clean and tighten all connections and joints.
5. Use megger to obtain ground resistance measurements and record.
6. Compare present readings with those made previously.
7. Repair or replace faulty equipment, re-check resistance readings.
8. Install additional equipment if necessary to obtain required grounding resistance readings.

COMPETENCY: Check, service and maintain adequate grounding systems to continue to meet the National Electrical Code requirements.

CRITERION: Can clean, adjust and tighten all connections and joints.

Can use megger to obtain ground resistance measurements and record.

Can compare present readings with those made previously.

Can repair or replace faulty equipment and reconnect to obtain proper grounding resistance levels.

Can classify all electrical loads in a building or operation in order to set priorities.

Can analyze total electrical operation to recommend appropriate load management control.

Can unlock and reconnect power source and remove safety tag.

Can sequence operate system to verify proper function of component parts and entire system.

Can readjust as necessary to realize maximum energy conservation within reasonable operating limits.

Can secure equipment housing covers.

TASK AREA: Maintenance

TASK L-45: Perform maintenance on electronic devices.

SUB-TASKS:

1. Locate, disconnect, lock-off and tag power source using appropriate equipment and following standard safety practices.
2. Remove housing covers.
3. Clean, with electrical solvent cleaner, adjust, and tighten all joints and connections.
4. Inspect for electrical arc damage.
5. Replace faulty components, if designed for field maintenance and/or replacement.
6. Install housing covers.
7. Remove lock-off and tag and reconnect power source.
8. Observe several operational cycles to be sure equipment is functioning properly.

COMPETENCY: Check, service and adjust electronic devices to function properly, according to manufacturer's instructions.

CRITERION: Can clean and adjust and tighten all connections and joints and interiors.

Can compare line and load ratings of equipment with manufacturer's data.

Can adjust or replace components to meet manufacturer's specifications.

Can check performance of equipment for inefficient energy consumption during each regular maintenance interval.

Can sequence operate equipment to assure proper function of devices.

Can secure equipment housing covers.

Can maintain equipment so that it operates efficiently and therefore is energy conserving.

TASK AREA: Maintenance

TASK L-46: Perform maintenance on lighting fixtures.

SUB-TASKS:

1. Locate, disconnect, lock-off and tag power source using appropriate equipment and following standard safety practices.
2. Open fixtures and inspect for overheating or indications of electrical arc damage.
3. Clean lens and reflectors.
4. Tighten connections and joints.
5. Replace ballasts showing signs of overheating.
6. Re-lamp fixture if required by maintenance cycle.
7. Check auxiliary starting aids, photo-cells and time clocks for proper operation and settings.
8. Close up fixtures.
9. Remove lock-off and tag and reconnect power source.
10. Check for efficient operation.

Note:

Energy efficient lamps, ballasts and improved efficient fixtures may prove more economical and energy conserving than maintaining the present lighting system. Age of equipment and changes in use of certain areas should be taken into consideration. Management may wish to consider retrofitting or modernization.

COMPETENCY: Perform maintenance on lighting fixtures to produce maximum light output at design level. (Note: Strong consideration should be given to replacing standard ballasts with energy conservation types, and re-lamping with energy conservation lamps.)

CRITERION: Can clean lamps and fixtures during regular maintenance interval so that lights operate at maximum efficiency.

Can replace lamps - consider energy efficient replacements.

Can replace ballasts - consider energy efficient type.

Can retrofit existing fixtures to accept energy efficient ballasts and lamps.

Can analyze proposed lighting and make recommendations for lowest energy consuming light for the job.

Can maintain equipment so that it operates efficiently and therefore is energy conserving.

65

TASK AREA: Maintenance

TASK L-47: Perform maintenance on DC machine.

SUB-TASKS:

1. Disconnect and lock-off power.
2. Mark and disconnect wires from motor.
3. Mark end bells.
4. Check brush wear and brush spring tension.
5. Check series field and shunt field for proper resistance and grounds.
6. Remove end bells.
7. Remove armature and check for grounds.
8. Check armature for shorts with growler.
9. Turn commutator if needed.
10. Clean motor with electrical solvent.
11. Lubricate bearings.
12. Reassemble motor.
13. Reconnect wires.
14. Reconnect power and test motor.

COMPETENCY: Perform maintenance on a DC machine to repair, replace or perform preventative maintenance so machine functions properly under operating conditions.

CRITERION: Can lock-off power and make safe for maintenance.

Can check DC machine and make preliminary assessment of maintenance to be done.

Can make necessary repairs to wiring or replacement of components such as bearings and brushes with correct parts to repair equipment.

Can lubricate DC machines using correct type lubricants and applying at correct locations only.

TASK AREA: Hazardous Locations

TASK M-48: Make installations in hazardous locations.

SUB-TASKS:

1. Select the proper materials for the codes classification listed on the plans and follow standard safety procedures.
2. Install the material and equipment to conform to job layout.
3. Locate seal-offs and special fittings as required for the installed equipment.
4. Install conductors and properly connect.
5. Test conductors for shorts and grounds.
6. Build and pour seal-offs and close up.
7. Properly secure outlet and enclosure covers to maintain codes classification rating.

COMPETENCY: Determine the correct materials to use in making an installation in an area which has been classified as being one of the three types of National Electrical Code hazardous locations.

CRITERION: Can identify material items acceptable for each class of hazardous location.

Can properly install these items in the applicable area:

- | | |
|----------------------|---------------------------|
| 1. Outlets | 6. Remote control devices |
| 2. Devices | 7. Switches |
| 3. Fixtures | 8. Signal systems |
| 4. Panels | 9. Heaters |
| 5. Motor controllers | |

Can properly install seal-off fittings in conduit runs according to the National Electrical Code.

86/87 67

TASK AREA: Load Calculations

TASK N-49: Make load calculations for residential.

SUB-TASKS:

1. Determine total area of house.
2. Apply watts/square foot to determine the lighting load.
3. Calculate small appliance branch circuit load.
4. Calculate laundry branch circuit load.
5. Calculate receptacle loads.
6. Calculate motor circuit loads.
7. Calculate fixed electric space heating loads.
8. Calculate fixed appliance loads (some examples listed below)
 - a. Water heater
 - b. Disposal
 - c. Dishwasher
 - d. Furnace
 - e. Attic fan
 - f. Water pump
9. Calculate clothes dryer load.
10. Calculate range, oven or other cooking appliance load.
11. Size branch circuits and overcurrent protective devices for loads being served.
12. Apply demand and diversity as well as continuous loading factors to determine feeder and service loads.
13. Size feeders, services and service entrance equipment and panels to serve the load calculated and conform to the National Electrical Code.
14. Size neutral and equipment grounding and service grounding conductors to conform to the National Electrical Code.

COMPETENCY: Can make the load calculations necessary to determine conductor size and overcurrent protective device ratings to comply with governing codes, ordinances, plans and specifications.

CRITERION: Can calculate the permissible load of:

1. Individual branch circuit
2. Feeder circuits
3. Service

Can size the conductor needed.

Can size the overcurrent protective device needed.

Can apply continuous load factors and demand factors correctly.

Can properly size the necessary neutral conductor.

Can properly size the necessary equipment grounding conductor.

69

TASK AREA: Load Calculations

TASK N-50: Make load calculations for commercial.

SUB-TASKS:

1. Determine total area of building.
2. Apply watts/square foot to determine the lighting load.
3. Calculate show window lighting load if applicable.
4. Calculate receptacle load.
5. Calculate motor loads.
6. Calculate fixed electric space heating loads.
7. Calculate comfort conditioning loads.
8. Calculate sign, outdoor/parking lot lighting loads.
9. Calculate special equipment loads.
10. Size branch circuits and overcurrent protective devices for loads being served.
11. Apply demand and diversity as well as continuous load factors to determine feeders and service size.
12. Size feeders, service and service entrance equipment and panels to serve the load calculated and conform to the National Electrical Code.
13. Size neutral and equipment grounding and service grounding conductors to conform to the National Electrical Code.

COMPETENCY: Can make the load calculations necessary to determine conductor size and overcurrent protective device ratings to comply with governing codes, ordinances, plans and specifications.

CRITERION: Can calculate the permissible load of:

1. Individual branch circuit
2. Feeder circuits
3. Service

Can size the conductor needed:

Can size the overcurrent protective device needed.

Can apply continuous load factors and demand factors correctly.

Can properly size the necessary neutral conductor.

Can properly size the necessary equipment grounding conductor.

TASK AREA: Load Calculations

TASK N-51: Make load calculations for industrial.

SUB-TASKS:

1. Determine the total area of the building.
2. Apply watts/square foot to determine the lighting load.
3. Calculate receptacles load.
4. Calculate building services motor loads.
5. Calculate fixed electric space heating loads.
6. Calculate comfort conditioning loads.
7. Calculate sign, outside/parking lot lighting loads.
8. Calculate production equipment loads.
9. Size branch circuit and overcurrent protective devices for loads being served.
10. Apply demand and diversity as well as continuous load factors to determine feeders and service size.
11. Size feeders, service and service entrance equipment and panels to serve the load calculated and conform to the National Electrical Code.
12. Size neutral and equipment grounding and service grounding conductors to conform to the National Electrical Code.

COMPETENCY: Can make the load calculations necessary to determine conductor size and overcurrent protective device ratings to comply with governing codes, ordinances, plans and specifications.

CRITERION: Can calculate the permissible load of:

1. individual branch circuit
2. feeder circuits
3. service

Can size the conductor needed.

Can size the overcurrent protective device needed.

Can apply continuous load factors and demand factors correctly.

Can properly size the necessary neutral conductor.

Can properly size the necessary equipment grounding conductor.

TASK AREA: Blueprint Reading and Estimating

TASK 0-52: Read blueprints to determine style, shape, location, and dimensions of structure.

SUB-TASKS:

1. Interpret blueprints to determine location of structure on the site.
2. Interpret blueprints to determine style and shape of structure and location of features within the structure.
3. Interpret blueprints to determine dimensions of structure.
4. Interpret blueprints to determine special construction specifications and instructions.
5. Interpret blueprints to determine special or unique features.

COMPETENCY: Read and interpret blueprints to determine style, shape, location, and dimensions of structure and accurately describe features to estimate materials, costs, and explain construction of building.

CRITERION: Can locate all features, their size, shape, and location to lay out building according to plans and specifications.

Can interpret blueprints to identify special features, specifications, and instructions and construct or make installations according to the plans.

TASK AREA: Blueprint Reading and Estimating

TASK 0-53: Read and interpret specifications

SUB-TASKS:

1. Read specifications to interpret conditions and special instructions.
2. Read specifications to interpret types and quality of materials.
3. Read specifications to interpret instructions on methods of construction.

COMPETENCY: Read and interpret specifications to determine conditions, type and quality of materials, and methods of construction.

CRITERION: Can accurately interpret specifications to understand the responsibility of the builder in construction of a feature or component.

Can accurately interpret specifications to determine type, grade and quality of materials and substitutes that may be used.

Can read specifications to interpret and carry out special instructions on how a feature or component of structure is to be constructed.

96/97

73

TASK AREA: Blueprint Reading and Estimating

TASK 0-54: Make sketches and layouts from descriptive instructions, drawing, and/or from measurements of existing structures.

SUB-TASKS:

1. Determine shape and features and make freehand sketches.
2. Dimension sketches for size and location of features.
3. Note sketches to provide instruction for materials, finishes, methods, and special information for construction.

COMPETENCY: Make sketches and layouts from descriptive instructions, drawings, and/or from measuring existing structures so sketches provide all information essential to build the object.

CRITERION: Can sketch three dimensional views, plans, and elevations that correctly describe shape, features, and location of features.

Can dimension sketches to provide all size and location dimensions needed to construct object.

Can add notes and instructions that clearly indicate materials, specifications, and information essential for completing drawing so object can be constructed.

98/99

74

TASK AREA: Blueprint Reading and Estimating

TASK 0-55: Read blueprints and specifications to determine electrical installations to be made in structure.

SUB-TASKS:

1. Interpret blueprints and specifications to determine location, type, and number of outlets.
2. Interpret blueprints and specifications to determine location, type, and number of lighting fixtures.
3. Interpret blueprints and specifications to determine location, type, and number of switches and controls.
4. Interpret blueprints and specifications to determine type and number of electrical devices such as heaters, doorbells, smoke detectors, security systems, fans, intercoms, etc. that must be installed by electrician.
5. Interpret blueprints to determine location of service entrance box.

COMPETENCY: Read blueprints and specifications to determine electrical installations to be made in structure for comparison to codes and ordinances and for discussion with electrician.

CRITERION: Can locate all outlets, identify type, and compare to code.

Can identify location for all lighting fixtures, type specified, and compare to code.

Can identify location of all switches and controls, type specified, and what appliance or device is connected to each switch or control.

TASK AREA: Blueprint Reading and Estimating

TASK 0-56: Estimate type and quantity of material needed for a given electrical system.

SUB-TASKS:

1. Identify various systems shown on the plans.
2. List the separate components which make up the system. These could include the following:
 - a. Service, cable and/or conduit and wire
 - b. Feeders
 - c. Branches
 - d. Panels and switchgear
 - e. Transformers
 - f. Devices and plates
 - g. Lighting fixtures
 - h. Grounding
 - i. Bus ducts
 - j. Underfloor ducts
 - k. Signal systems
 - 1) Clock
 - 2) Sound
 - 3) Fire alarm
 - 4) C.C.T.V.
 - 5) Energy management
 - l. Telephone
 - m. Starters and controllers
 - n. Switches and disconnects
 - o. Motor connections
3. Determine the quantity of each item by measure of length or count of number and record their quantities.
4. Determine the type and quantity of hangers and fasteners needed.
5. Summarize the various systems and individual items of equipment to arrive at a total list of materials needed for the job.
6. Calculate cost of materials.

COMPETENCY: Make a material take-off of all items necessary to completely install the electrical system; to comply with codes, ordinances, plans and specifications.

CRITERION: Can review plans and determine the necessary categories to be listed:

1. Service
2. Panels
3. Feeders
4. Branches
5. Outlets
6. Switches and receptacles
7. Motors
8. Special outlets
9. Fixtures
10. Grounding

Can count and measure individual items:

1. Allow for "make up" of wires in outlets and panels
2. Allow for "scrap" and for up-and-down distances
3. Include hangers and fasteners

Can calculate correct type of equipment and materials and calculate quantity and cost within a predetermined margin of error.

77

TASK AREA: Blueprint Reading and Estimating.

TASK 0-57: Estimate labor requirements for installation of a given electrical system.

SUB-TASKS:

1. Obtain complete material take-off of each item of equipment required to make the installation.
2. Apply proven labor units to each item of equipment.
3. Apply shop, job and market "factors" to tailor the estimate to the job.
4. Apply payroll taxes and insurance costs necessary to do the job.
5. Apply overhead and operating costs to estimate.
6. Add expected profit to estimate and have it reviewed by someone else for mathematical calculation and extensions as well as an "overall-check" for possible "missed items".

COMPETENCY: Make an estimate of man-hours of labor required to completely install the electrical system to comply with governing codes, ordinances, plans and specifications.

CRITERION: Can apply labor units to material take-off.
Consideration and factoring needed for:

1. Height of work	5. Labor force available
2. Weight of materials	6. Prior experience
3. Complexity of job	7. Tools and equipment needed
4. Weather	

Can apply payroll taxes and insurances necessary to complete the job.

TASK AREA: Rehabilitation Work and Adding Circuits

TASK P-58: Make modifications and extensions to existing circuits.

SUB-TASKS:

1. Determine added loads.
2. Determine whether service entrance and equipment is adequate to accommodate added loads.
3. Check existing circuits to see if new loads can be added to existing circuits.
4. Determine modifications/additions to be made to accept additional loads.
5. Select and install proper equipment.
6. Run/extend branch circuits to serve added loads.
7. Make proper conductor connections to equipment being served.
8. Provide equipment grounding as required by the National Electrical Code.
9. Re-seal envelope penetrations of building insulation to maintain energy efficiency.

COMPETENCY: Make modifications to existing equipment, extensions to existing circuits, and add new equipment and circuits to comply with governing codes, ordinances and job requirements.

CRITERION: Can calculate proposed loads to properly size circuit conductors and overcurrent protective devices.

Can calculate existing loads and determine adequacy of service size and service equipment for proposed additions.

Can route and install circuits, devices and equipment to comply with the National Electrical Code and job requirements.

TASK AREA: Special Occupancies and Equipment

TASK Q-59: Install electrical equipment and circuits for special occupancy areas and equipment.

SUB-TASKS:

1. Determine the special occupancy area or the special equipment.
2. Make needed calculations to determine overcurrent protective devices, conductor size and switch or controller sizes as required.
3. Select and install the proper wiring system and related equipment to suit the area or equipment involved.
4. Make the correct connections to the equipment.
5. Install and connect necessary grounding and bonding required for the special occupancy area or equipment.
6. Test and verify that the equipment performs its intended function and will safely work in the area in which it is installed.

COMPETENCY: Identify the special occupancy area, or equipment select and install the correct wiring and equipment, make connections properly, and comply with governing codes and ordinances, plans and specifications. These areas and equipment include swimming pools, welders, health care facilities, theaters, mobile homes and recreational vehicles and mobile home and recreational vehicle parks, boats and marinas, generators, elevators, and irrigation machines.

CRITERION: Can identify the special occupancy area or recognize the special equipment.

Can make the necessary load calculations to adequately insure the equipment and installation will comply with governing codes and ordinances, plans, and specifications.

Can select and install the correct wiring system to serve the equipment.

Can make the proper connections to the equipment.

Can install the required grounding and bonding required for the special occupancy or equipment.

80

108/109

CHAPTER III

CURRICULUM GUIDE

The Electrical Installation and Maintenance curriculum has been designed as a vocational program with emphasis on the development of specific skills related to employment in the electrical trades. Content has been arranged to provide for the development of increasing levels of skills as the student progresses in the program.

Related courses such as communication skills, blueprint reading, math and applied science have been included in the curriculum to support the knowledge and skills required by job level as indicated by employers.

The material provided in this chapter includes the curriculum description, job description, course listing by quarters, task listing for the curriculum, and a description of each course with a task listing for that course.

The tasks have been organized by courses to indicate where they should be taught in the curriculum. That is to say that the task listing for a course indicates that the knowledge and skills necessary to perform those tasks will be taught in that course. In many cases a task is listed for several courses indicating that the teaching of the knowledge and skills necessary to perform that task takes place in several courses before it is completed.

This curriculum guide should be utilized as a reference for those individuals in the institutions who are involved in curriculum development and instruction. It is an example of how the teaching of each task has been incorporated into this competency-based curriculum model. There are many different ways to organize the competencies within the courses. This guide illustrates one method of organization that emphasizes integration of the subjects and provides for skills building as the student progresses through the program. The final sequence of competencies in relation to the courses and amount of emphasis that each competency receives in the total curriculum should be determined after consultation with a local advisory committee of employers and employees in the electrical installation and maintenance field.

ELECTRICAL INSTALLATION AND MAINTENANCE

INTRODUCTION

Purpose of Curriculum

The Electrical Installation and Maintenance curriculum provides training in the basic knowledge, fundamentals and practices involved in electrical trades. A background in both laboratory skills and related information is included. An understanding of electric circuits, wiring, insulation, motors, generators, transformers, energy conservation and blueprint reading are integral parts of this curriculum. A thorough understanding and appreciation of safety and first aid practices, the National Electrical Code, and energy load management are included. Emphasis is also placed on the application and use of special electrician hand tools, electrical heat and electrical control devices and systems.

The curriculum also includes business procedures and practices and communication skills that are essential for job advancement with experience.

Job Description and Requirements

The graduates of the electrical trades program will be qualified to enter an electrical trade as on-the-job trainees or apprentices where they will assist in the planning, lay out, installation, check out and maintenance of systems in residential, commercial or industrial plants. They will have an understanding of the fundamentals of the National Electrical Code regulations related to wiring installations, electrical circuits and the measurements of voltage, current, power and power factor of single and polyphase alternating circuits. They will have a basic knowledge of motor and motor control systems; industrial electronic control systems; business procedures, organization, and practices; communication skills; and the necessary background to be able to advance with experience. They will also have an understanding of electrical conservation and load management as applied to both residential and industrial uses.

ELECTRICAL INSTALLATION AND MAINTENANCE

SUGGESTED CURRICULUM BY QUARTERS

<u>Course Title</u>	<u>Hours Per Week</u>			<u>Quarter Hours Credit</u>
	<u>Class</u>	<u>Lab.</u>	<u>Clinic/Shop</u>	
<u>FIRST QUARTER</u>				
ELC 1112 Direct and Alternating Current	5	0	12	9
ENG 1101 Reading Improvement	2	0	0	2
MAT 1115 Electrical Mathematics	5	0	0	5
PHY 1103 Applied Science	3	2	0	4
	<u>15</u>	<u>2</u>	<u>12</u>	<u>20</u>
<u>SECOND QUARTER</u>				
ELC 1113 Alternating Current and Direct Current Machines and Controls	5	0	12	9
DFT 1110 Blueprint Reading: Building Trades	0	0	3	1
ENG 1102 Communication Skills	3	0	0	3
PHY 1102 Applied Science	3	2	0	4
	<u>11</u>	<u>2</u>	<u>15</u>	<u>17</u>
<u>THIRD QUARTER</u>				
ELC 1124 Residential Wiring	5	0	9	8
ELN 1118 Industrial Electronics	3	0	6	5
PSY 1101 Human Relations	3	0	0	3
DFT 1113 Blueprint Reading: Electrical	0	0	3	1
	<u>11</u>	<u>0</u>	<u>18</u>	<u>17</u>
<u>FOURTH QUARTER</u>				
ELC 1125 Commercial and Industrial Wiring	5	0	12	9
ELN 1119 Industrial Electronics	3	0	6	5
BUS 1103 Small Business Operations	3	0	0	3
	<u>11</u>	<u>0</u>	<u>18</u>	<u>17</u>
	<u>48</u>	<u>4</u>	<u>63</u>	<u>71</u>

TASKS

ELECTRICAL INSTALLATION AND MAINTENANCE

SERVICE ENTRANCES

- A-11: Install service using metallic conduit and wire.
- A-12: Install service using non-metallic service entrance cable.
- A-13: Install service using non-metallic conduit and wire.

FEEDERS

- B-14: Install feeders using metallic conduit and wire.
- B-15: Install feeders using non-metallic conduit and wire.
- B-16: Install feeders using non-metallic cable.

PANELBOARDS AND SWITCHBOARDS

- C-17: Install panelboards and switchboards.

DUCT SYSTEMS

- D-18: Install bus duct systems.
- D-19: Install underfloor duct system.

GROUNDING

- E-20: Ground non-metallic conduit raceway systems.
- E-21: Ground devices, fixtures and equipment.
- E-22: Ground transformers.

BRANCH CIRCUITS

- F-23: Install branch circuit using metallic conduit and wire.
- F-24: Install branch circuit using non-metallic conduit and wire.
- F-25: Install branch circuit using non-metallic cable.
- F-26: Install local control switches and plates.
- F-27: Install receptacles and plates.
- F-28: Install fixtures and lamps.
- F-29: Install outside lighting.

LOW VOLTAGE CONTROL SYSTEMS

- G-30: Install low voltage control system.

SIGNAL SYSTEMS

- H-31: Install signal systems.

TRANSFORMERS

- I-32: Install transformers.

ELECTRIC HEATING

- J-33: Install electric heaters.
- J-34: Install electric heat cables and mats.

MOTORS AND CONTROLS

- K-35: Make motor load calculations for single and three phase AC motors, DC motors.
- K-36: Install starters, controllers, disconnects and individual overcurrent devices.
- K-37: Install motors.
- K-38: Install relays, timing devices and other auxiliary pilot devices.

MAINTENANCE

- L-39: Perform maintenance on panelboards and switchboards.
- L-40: Perform maintenance of motor controllers and operator control switches.
- L-41: Perform maintenance on single phase and three phase motors.
- L-42: Perform maintenance on transformers - single phase and three phase.
- L-43: Perform maintenance on load management controllers.
- L-44: Perform maintenance on grounding systems.
- L-45: Perform maintenance on electronic devices.
- L-46: Perform maintenance on lighting fixtures.
- L-47: Maintenance on DC machine.

HAZARDOUS LOCATIONS

- M-48: Make installations in hazardous locations.

LOAD CALCULATIONS

- N-49: Make load calculations for residential.
- N-50: Make load calculations for commercial.
- N-51: Make load calculations for industrial.

BLEUPRINT READING AND ESTIMATING

- O-52: Read blueprints to determine style, shape, location, and dimensions of structure.
- O-53: Read and interprets specifications.
- O-54: Make sketches and layouts from descriptive instructions, drawings, and/or from measurements of existing structures.
- O-55: Read blueprints and specifications to determine electrical installations to be made in structure.

0-56: Estimate type and quantity of material needed for a given electrical system.

0-57: Estimate labor requirements for installation of a given electrical system.

REHABILITATION WORK AND ADDING CIRCUITS

P-58: Make modifications and extensions to existing circuits.

SPECIAL OCCURANCIES AND EQUIPMENT

Q-59: Install electrical equipment and circuits for special occupancy areas and equipment.

ELC 1112 DIRECT AND ALTERNATING CURRENT

<u>Course Description</u>	<u>Class Hours</u>	<u>Lab Hours</u>	<u>C1/Shop Hours</u>	<u>Quarter Hours Credit</u>
	5	0	12	9

A study of the electrical structure of matter and electron theory; the relationship between voltage, current, and resistance in series, parallel, and series-parallel circuits. An analysis of direct current circuits by Ohm's Law and Kirchhoff's Law. A study of the sources of direct current voltage potentials. Fundamental concepts of alternating current flow, reactance, impedance, phase angle, power, and resonance. Analysis of alternating current circuits.

Prerequisite: None.

Tasks

The following tasks are introduced in this course and are continued in additional courses.

- E-21 Ground devices, fixtures and equipment
- F-26 Install local control switches and plates
- F-27 Install receptacles and plates

120/121

87

ENG 1101 READING IMPROVEMENT

Course Description

A concentrated effort to improve the student's ability to comprehend what he reads by training him to read more rapidly and accurately. Special machines are used for class drills to broaden the span of recognition, to increase eye coordination and work group recognition, and to train for comprehension in larger units. Reading faults of the individual are analyzed for improvement, and principles of vocabulary building are stressed.

Prerequisite: None

Objectives

To broaden and increase the span of recognition through eliminating common reading faults, and to develop the reader's understanding and skill in techniques for rapid reading and comprehension.

<u>Major Divisions</u>	<u>Class Hours</u>	<u>Lab Hours</u>	<u>Cl/Shop Hours</u>	<u>Quarter Hours Credit</u>
	2	0	0	2

- I. Introduction
- II. Common faults of slow readers, and their correction
- III. Broadening the span of recognition
- IV. Accuracy of interpreting symbol forms
- V. Apprehension and eye-hand coordination
- VI. Building word recognition ability
- VII. Numbers and letters
- VIII. Vocabulary building
- IX. Continuing improvement of speed and comprehension

122/123

MAT 1115 ELECTRICAL MATHEMATICS

Course Description

A study of fundamental concepts of algebra; basic operations of addition, subtraction, multiplication, and division; solution of first order equations, use of letters and signs, grouping, factoring, exponents, ratios, and proportions; solution of equations, algebraically and graphically; a study of logarithms and use of tables; an introduction to trigonometric functions, and their application to right angles; and a study of vectors for use in alternating current.

Prerequisite: None

Objectives

To develop an understanding of the fundamentals of algebra and trigonometry and their applications in solving practical problems in the electrical field.

<u>Major Divisions</u>	<u>Class Hours</u>	<u>Lab Hours</u>	<u>Cl/Shop Hours</u>	<u>Quarter Hours Credit</u>
I. Review of arithmetic	5	0	0	5
II. Algebraic expressions and operations				
III. Units (of measurement) and dimensions				
IV. Equations				
V. Special products and factoring				
VI. Algebraic fractions				
VII. Fractional equations				
VIII. Simultaneous equations				
IX. Exponents and radicals				
X. Angles				
XI. Trigonometric functions				
XII. Tables of functions				
XIII. Solution of right triangles				
XIV. Periodic functions				
XV. Elementary plane vectors				

PHY 1101 APPLIED SCIENCE

Course Description

An introduction to physical principles and their application in industry. Topics in this course include measurement; properties of solids, liquids, and gases; and basic electrical principles.

Prerequisite: None

Objectives

To develop an understanding of the physical principles including the states and characteristics of matter, measurement and applications of those principles.

<u>Major Divisions</u>	<u>Class Hours</u>	<u>Lab Hours</u>	<u>C1/Shop Hours</u>	<u>Quarter Hours Credit</u>
I. Types of measurement	3	2	0	4
II. Development and use of the "scientific method"				
III. Principles and uses of machines				
IV. Solids, liquids and gases				
V. Types of energy				

ELC 1113 ALTERNATING CURRENT AND DIRECT CURRENT MACHINES AND CONTROLS

	<u>Class Hours</u>	<u>Lab Hours</u>	<u>CI/Shop Hours</u>	<u>Quarter Hours Credit</u>
<u>Course Description</u>	5	0	12	9

Provides fundamental concepts in single and polyphase alternating current circuits, voltages, currents, power measurements, transformers, and motors. Instruction in the use of electrical test instruments in circuit analysis. The basic concepts of AC and DC machines and simple system controls. An introduction to the type control used in small appliances such as thermostats, timers, or sequencing switches.

Prerequisites: ELC 1112, MAT 1115

Tasks

The following tasks are introduced in this course and are continued in additional courses.

- B-14 Install feeders using metallic conduit and wire
- B-15 Install feeders using non-metallic conduit and wire
- B-16 Install feeders using non-metallic cable
- C-17 Install panelboards and switchboards
- E-20 Ground non-metallic conduit raceway systems
- E-22 Ground transformers
- F-23 Install branch circuit using metallic conduit and wire
- F-24 Install branch circuit using non-metallic conduit and wire
- F-25 Install branch circuit using non-metallic cable
- G-30 Install low voltage control system
- H-31 Install signal systems
- K-35 Make motor load calculations for single and three phase AC motors, DC motors
- K-36 Install starters, controllers, disconnects and individual overcurrent devices
- K-37 Install motors
- K-38 Install relays, timing devices and other auxiliary pilot devices

- L-39 Perform maintenance on panelboards and switchboards
- L-40 Perform maintenance of motor controllers and operator control switches
- L-41 Perform maintenance on single phase and three phase motors
- L-42 Perform maintenance on transformers - single phase and three phase
- L-43 Perform maintenance on load management controllers
- L-44 Perform maintenance on grounding systems
- O-56 Estimate type and quantity of material needed for a given electrical system
- O-57 Estimate labor requirements for installation of a given electrical system.

The following tasks were introduced and taught in previous courses and will be taught in this and other courses.

- E-21 Ground devices, fixtures and equipment
- F-26 Install local control switches and plates
- F-27 Install receptacles and plates

DFT 1170 BLUEPRINT READING: BUILDING TRADES

Course Description

Principles of interpreting blueprints and trade specifications common to the building trades. Development of proficiency in making three view and pictorial sketches.

Prerequisite: None

Objectives

To develop an understanding of the types of information presented on trade blueprints and to develop skill in interpretation of trade blueprints. To develop an ability to express ideas graphically using freehand sketches.

<u>Major Divisions</u>	<u>Class Hours</u>	<u>Lab Hours</u>	<u>Cl/Shop Hours</u>	<u>Quarter Hours Credit</u>
	0	0	3	1

- I. Introduction to blueprint reading
- II. Shape description method in drawings
- III. Representative of dimensions and finish
- IV. Pictorial drawing
- V. Working drawings: procedures and techniques

Tasks

The following tasks are introduced in this course and are continued in additional courses:

- 0-52 Read blueprints to determine style, shape, location and dimensions of structure
- 0-53 Read and interpret specifications
- 0-54 Make sketches and layouts from descriptive instructions, drawings, and/or from measurements of existing structures

ENG 1102 COMMUNICATION SKILLS

Course Description

Designed to promote effective communication through correct language usage in speaking and writing.

Prerequisite: ENG 1101

Objectives

To develop the student's ability to communicate successfully with other individuals, to think more clearly, to solve problems better, and to reason more forcefully in work problems pertaining to his life.

Major Divisions

Class
Hours
3

Lab
Hours
6

Cl/Shop
Hours
0

Quarter
Hours
Credit
3

- I. Sentence structure
- II. Written expression.
- III. Talking and listening
- IV. The report form

PHY 1102 APPLIED SCIENCE

Course Description

The second in a series of two courses of applied physical principles. Topics introduced in this course are heat and thermometry, and principles of force, motion, work, energy, and power.

Prerequisite: PHY 1101

Objectives

To develop an understanding of the scientific concepts basic to heat and its conversion to work and to be able to make practical applications of the concepts basic to machines and mechanisms.

<u>Major Divisions</u>	<u>Class Hours</u>	<u>Lab Hours</u>	<u>Cl/Shop Hours</u>	<u>Quarter Hours Credit</u>
	3	2	0	4
I. Heat and thermometry				
II. Thermal expansion				
III. Change of phase				
IV. Transfer of heat				
V. Heat and work				
VI. Common industrial engines				
VII. Physical concepts applicable to machines and mechanisms				
VIII. Energy and work				
IX. Simple machines				
X. Screw thread				
XI. Gear trains, simple and compound				
XII. Simple and compound machines				
XIII. Mechanical power transmission and effects of friction and lubrication.				

ELC 1124 RESIDENTIAL WIRING

<u>Course Description</u>	<u>Class Hours</u>	<u>Lab Hours</u>	<u>Cl/Shop Hours</u>	<u>Quarter Hours Credit</u>
	5	0	9	8

Provides instruction and application in the fundamentals of blueprint reading, planning, lay out, and installation of wiring in residential applications such as services, switchboards, lighting, fusing, wire sizes, branch circuits, conduits, National Electrical Code regulations, in actual building mock-ups.

Prerequisites: ELC 1113, DFT 1110

Tasks

The following tasks are introduced in this course with development of basic competency to perform those tasks completed in this course.

- N-49 Make load calculations for residential

The following tasks are introduced in this course and are continued in additional courses.

- A-11 Install service using metallic conduit and wire
- A-12 Install service using non-metallic service entrance cable
- A-13 Install service using non-metallic conduit and wire
- F-28 Install fixtures and lamps
- F-29 Install outside lighting
- J-33 Install electric heaters
- J-34 Install electric heat cables and mats
- L-46 Perform maintenance on lighting fixtures
- M-48 Make installations in hazardous locations
- P-54 Make modifications and extensions to existing circuits
- Q-55 Install electrical equipment and circuits for special occupancy areas and equipment

The following tasks were introduced and taught in previous courses and will be taught in this and other courses.

- B-14 Install feeders using metallic conduit and wire

- B-15 Install feeders using non-metallic conduit and wire
- B-16 Install feeders using non-metallic cable
- C-17 Install panelboards and switchboards
- E-20 Ground non-metallic conduit raceway systems
- E-21 Ground devices, fixtures and equipment
- E-22 Ground transformers
- F-23 Install branch circuit using metallic conduit and wire
- F-24 Install branch circuit using non-metallic conduit and wire
- F-25 Install branch circuit using non-metallic cable
- F-26 Install local control switches and plates
- F-27 Install receptacles and plates
- G-30 Install low voltage control system
- H-31 Install signal systems
- K-36 Install starters, controllers, disconnects and individual overcurrent devices
- K-38 Install relays, timing devices and other auxiliary pilot devices
- L-39 Perform maintenance on panelboards and switchboards
- L-40 Perform maintenance of motor controllers and operator control switches
- L-41 Perform maintenance on single phase and three phase motors
- L-44 Perform maintenance on grounding systems
- D-56 Estimate type and quantity of material needed for a given electrical system
- D-57 Estimate labor requirements for installation of a given electrical system

ELN 1118 INDUSTRIAL ELECTRONICS

<u>Course Description</u>	<u>Class Hours</u>	<u>Lab Hours</u>	<u>Cl/Shop Hours</u>	<u>Quarter Hours Credit</u>
	3	0	6	5

Basic theory, operating characteristics, and application of solid-state electronic theory use in circuit protective devices, control circuits such as relays, limit switches, sensing devices and an understanding of basic electro-mechanical logic. Disassemble, replace parts and reassemble all types of electro-mechanical devices.

Prerequisite: ELC 1113

Tasks

The following tasks are introduced in this course and are continued in additional courses.

L-45 Perform maintenance on electronic devices

The following tasks were introduced and taught in previous courses and will be taught in this and other courses.

K-36 Install starters, controllers, disconnects and individual overcurrent devices

PSY 1101 HUMAN RELATIONS

Course Description

A study of basic principles of human behavior. The problems of the individual are studied in relation to society, group membership, and relationships within the work situation.

Prerequisite: None

Objectives

To develop an understanding of the principles of human behavior as applied to interpersonal relationships on the job and as applied to the total behavior of an individual.

To gain the ability to evaluate oneself and carry out a program of self improvement.

Major Divisions

<u>Class Hours</u>	<u>Lab Hours</u>	<u>Cl/Shop Hours</u>	<u>Quarter Hours Credit</u>
3	0	0	3

- I. Understanding the meaning of "human relations" and "personality"
- II. Identifying and understanding the sources of problems in human relations
- III. Human relations and organization
- IV. Speech and conversation
- V. Physical elements of speech
- VI. Effective speech
- VII. Intelligent behavior
- VIII. Motives and emotions
- IX. Emotional conflict and adjustment
- X. The search for adjustment
- XI. Broadening your interests
- XII. Good health and posture

XIII. Good grooming and dress

XIV. Good manners

XV. Effective personality

XVI. Role of management in promoting desirable working relations.

XVII. Suggested problems in human relations.

100

DFT 1113 BLUEPRINT READING: ELECTRICAL

<u>Course Description</u>	<u>Class Hours</u>	<u>Lab Hours</u>	<u>Cl/Shop Hours</u>	<u>Quarter Hours Credit</u>
	0	0	3	1

Interpretation of schematics, diagrams and blueprints applicable to electrical installations with emphasis on electrical plans for domestic and commercial buildings. Sketching schematics, diagrams, and electrical plans for electrical installations using appropriate symbols and notes according to the applicable codes will be a part of this course.

Prerequisite: DFT 1110

Tasks

The following tasks are introduced in this course and are continued in additional courses.

- N-50 Make load calculations for commercial
- N-51 Make load calculations for industrial

The following tasks were introduced and taught in previous courses and will be taught in this and other courses.

- N-49 Make load calculations for residential
- O-52 Read blueprints to determine style, shape, location, and dimensions of structure
- O-53 Read and interpret specifications
- O-54 Make sketches and layouts from descriptive instructions, drawing, and/or from measurements of existing structures
- O-56 Estimate type and quantity of material needed for a given electrical system
- O-57 Estimate labor requirements for installation of a given electrical system

10101

ELC 1125 COMMERCIAL AND INDUSTRIAL WIRING

<u>Course Description</u>	<u>Class Hours</u>	<u>Lab Hours</u>	<u>C1/Shop Hours</u>	<u>Quarter Hours Credit</u>
	5	0	12	9

Lay out, planning, and installation of wiring systems in commercial and industrial complexes, with emphasis upon blueprint reading and symbols, the related National Electrical Codes, and the application of the fundamentals to practical experience in wiring, conduit preparation, and installation of simple systems. Causes of electrical energy waste and methods to improve operating efficiency.

Prerequisites: ELN 1118, ELC 1124

Tasks

The following tasks are introduced in this course with development of basic competency to perform those tasks completed in this course.

- I-32 Install transformers
- L-47 Maintenance on DC machine

The following tasks were introduced and taught in previous courses, and development of the basic competency to perform these tasks will be completed in this course.

- A-11 Install service using metallic conduit and wire
- A-12 Install service using non-metallic service entrance cable
- A-13 Install service using non-metallic conduit and wire
- B-14 Install feeders using metallic conduit and wire
- B-15 Install feeders using non-metallic conduit and wire
- B-16 Install feeders using non-metallic cable
- C-17 Install panelboards and switchboards
- D-18 Install bus duct systems
- D-19 Install underfloor duct system
- E-20 Ground non-metallic conduit raceway systems

11/14/145

- E-21 Ground devices, fixtures and equipment
- E-22 Ground transformers
- F-23 Install branch circuit using metallic conduit and wire
- F-24 Install branch circuit using non-metallic conduit and wire
- F-25 Install branch circuit using non-metallic cable
- F-26 Install local control switches and plates
- F-27 Install receptacles and plates
- F-28 Install fixtures and lamps
- F-29 Install outside lighting
- G-30 Install low voltage control system
- H-31 Install signal systems
- J-33 Install electric heaters
- J-34 Install electric heat cables and mats
- K-35 Make motor load calculations for single and three phase AC motors; DC motors
- K-36 Install starters, controllers, disconnects and individual overcurrent devices
- K-37 Install motors
- K-38 Install relays, timing devices and other auxiliary pilot devices
- L-39 Perform maintenance on panelboards and switchboards
- L-40 Perform maintenance of motor controllers and operator control switches
- L-41 Perform maintenance on single phase and three phase motors
- L-42 Perform maintenance on transformers - single phase and three phase
- L-43 Perform maintenance on load management controllers
- L-44 Perform maintenance on grounding systems
- L-45 Perform maintenance on electronic devices
- L-46 Perform maintenance on lighting fixtures

- M-48 Make installations in hazardous locations
- N-50 Make load calculations for commercial
- N-51 Make load calculations for industrial
- O-56 Estimate type and quantity of material needed for a given electrical system
- O-57 Estimate labor requirements for installation of a given electrical system
- P-54 Make modifications and extensions to existing circuits
- Q-55 Install electrical equipment and circuits for special occupancy areas and equipment

ELN 1119 INDUSTRIAL ELECTRONICS

<u>Course Description</u>	<u>Class Hours</u>	<u>Lab Hours</u>	<u>CI/Shop Hours</u>	<u>Quarter Hours Credit</u>
	3	0	6	5

Basic industrial electronic systems, such as motor controls, alarm systems, heating systems and controls, magnetic amplifier controls, welding control systems and other basic solid-state types of systems commonly found in most industries. Energy management control systems.

Prerequisite: ELN 1118

Tasks

The following tasks were introduced and taught in previous courses, and development of the basic competency to perform these tasks will be completed in this course.

- G-30 Install low voltage control system
- H-31 Install signal systems
- K-36 Install starters, controllers, disconnects and individual overcurrent devices
- K-38 Install relays, timing devices and other auxiliary pilot devices
- L-43 Perform maintenance on load management controllers
- L-45 Perform maintenance on electronic devices

148/149 105

BUS 1103 SMALL BUSINESS OPERATIONS

Course Description

An introduction to the business world, problems of small business operation, basic business law, business forms and records, financial problems, ordering and inventorying, layout of equipment and offices, methods of improving business, and employer-employee relations.

Prerequisite: None

Objectives

To develop an appreciation and understanding of small business and to develop a knowledge of the general procedures necessary for small business operations.

<u>Major Divisions</u>	<u>Class Hours</u>	<u>Lab Hours</u>	<u>Cl/Shop Hours</u>	<u>Quarter Hours Credit</u>
	3	0	0	3

- I. Introduction
- II. Problems of small business operation
- III. Basic business law
- IV. Business forms and records
- V. Financial problems
- VI. Location problems
- VII. Ordering and inventorying
- VIII. Layout
- IX. Improving your business
- X. Employer-employee relations

60/151 106

APPENDICES

107

152/153



DEPARTMENT OF
COMMUNITY COLLEGES
NORTH CAROLINA STATE BOARD OF EDUCATION
RALEIGH 27611

September 10, 1976

TO: North Carolina Electrical Contractors
FROM: Larry W. Fuqua, Assistant Director for
Vocational and Apprenticeship Programs
SUBJECT: Career Opportunity Survey

The Program Development Division, Department of Community Colleges, is conducting a project to determine the competencies required by employers in order for their employees to be successful on the job. This project is designed to: (1) develop a validated list of tasks performed by employees in a given job; (2) develop from the tasks, competencies which are required to perform successfully in the job; (3) develop curriculum guidelines; and (4) develop and/or revise curriculum materials based on the guidelines to assist educational personnel in providing quality occupational education programs.

The first step in this project is to determine the employment opportunities that are available to graduates of particular programs. For the Electrical Installation and Maintenance graduate, there is a limited list of job titles. If you know other job titles that you consider appropriate please list them. Your response to this survey will contribute to the identification of jobs that do exist.

After you have completed the survey, please return in the stamped, self-addressed envelope by September 21, 1976. Your responses will be compiled with the responses of other individuals completing the survey, with no individual responses identified.

I will appreciate your participation and involvement with this project.

LWF/bc

Enclosure

108

134/155

CAREER OPPORTUNITY SURVEY

The following employment opportunities have been identified as being possible careers open to individuals in the Electrical Installation and Maintenance curriculum. These opportunities may or may not exist.

Please indicate your opinion as to whether these employment opportunities do exist by checking (✓) the yes or no block next to the career identified. Please add additional opportunities that do exist, but were omitted from the careers that are listed.

D.O.T. Code *	Career Opportunity	Yes	No	Comments
824.281	Electrician			
829.887	Electrician Helper			
721.281	Electric Motor Repairman			
824.281	Electrician, Apprentice			
821.131	Electrician, Construction			
	Foreman			

*Dictionary of Occupational Titles, Third Edition.

156/157

109

CAREER OPPORTUNITY SURVEY
ELECTRICAL INSTALLATION AND MAINTENANCE CURRICULUM
(Tabulations)

Career Opportunity

D.O.T. Code*	Occupational Title	Yes	No	No Comment
828.281	Electrician	39	1	
829.887	Electrician Helper	36	1	3
721.281	Electric Motor Repairman	26	3	11
824.281	Electrician, Apprentice	37		2
821.131	Electrician, Construction Foreman	31	3	5
	Electrician, General Superintendent	1		
	Electrician, Controls Specialist	3		
	Electrician, Appliance Serviceman	1		
	Electrician, Lineman	2		
	Electrician, Estimator	5		
	Electrician, Foreman, Lineman	1		
	Electrician, Control Technician	1		
	Building Maintenance	1		
	Electrical Stock Room Clerk	1		
	Electrical Stock Pricing Clerk	1		
	Electrician, Designer	1		
	Electrician, Buyer	1		
	Electrical Supply Salesman	1		
	Electrical Contractor	1		

*Dictionary of Occupational Titles, Third Edition.

COMMENTS

Your Career Opportunity Survey is great! We're finally getting around to finding out just where we can place the people going through our Technical Institutes and Community Colleges.

All regularly in demand.

I do not believe that boys can go to school to learn the Electrical Trade without on-the-job experience; therefore, these indicated jobs do exist, but only persons with on-the-job experience can qualify.

Boys going to electrical schools can advance faster than boys who do not go to school, however they must start on the bottom just like everyone else.

This workshop was presented as a part of the Energy Conservation Curriculum and Short Course Project of the Occupational Program Services Section, North Carolina Department of Community Colleges.

ELECTRICAL INSTALLATION AND MAINTENANCE WORKSHOP

Project Director: Mr. Roger G. Worthington
Curriculum Coordinator: Dr. Larry W. Fuqua
Project Coordinator: Ms. Peggy M. Ball

October 27, 1980
JANE S. MCKIMMON CENTER
NORTH CAROLINA STATE UNIVERSITY

Sponsored by the North Carolina Department of Community Colleges, in cooperation with the North Carolina Energy Division, with funds granted by the U.S. Department of Energy (DOE) pursuant to the provisions of the Energy Policy and Conservation Act (EPCA) PL 94-163, and/or the Energy Conservation and Production Act (ECPA) PL 94-385.

OCCUPATIONAL PROGRAM SERVICES
NORTH CAROLINA DEPARTMENT OF COMMUNITY COLLEGES
RALEIGH, NORTH CAROLINA

BASIC ELECTRICAL EQUIPMENT LIST

16 STUDENTS

<u>ITEM NO.</u>	<u>QUANTITY</u>	<u>DESCRIPTION</u>
1	1	Motor control educational trainer
2	1	Basic electricity trainer
3	1	Circuit trainer
4	1	Industrial electronic teaching
5	1	Electrodemonstrator set
6	1	Motor controls power transmission system
7	1	Lab power panel
8	3	DC motor control unit
9	3	AC motor control unit

INSTRUMENTS AND METERS

10	1	DC Milliammeters
10a	1	AC Milliammeters
11	2	AC Ammeters
12	1	DC Ammeters
13	2	Multimeter
14	2	Low-Ohmmeter
15	2	AC Voltmeter
16	1	AC-DC Volt-Wattmeter
17	6	Volt-Ammeter
18	1	Microamp meter

<u>ITEM NO.</u>	<u>QUANTITY</u>	<u>DESCRIPTION</u>
19	1	Megger tester
20	1	Motor rotation indicator
21	1	Circuit tester meter
22	1	Phase sequence meter
23	1	Light meter
24	1	Single ϕ frequency meter
25	1	Three ϕ wattmeter
26	1	Digital readout clip-on ammeter
27	1	VAR meter
28	1	Conduit bender
29	1	Hydraulic knockout cutter
30	1	Electric linesman's safety belt
31	2 pr.	Linesman's pole climbers
32	1	Transister checker
33	1	Tube checker
34	2	Strobe light
35	6	Pipe threader set
36	3	Heavy duty pipe cutter
37	3	Burring reamer
38	3	Pipe reamer
39	6	Folding tripod vise
40	6	Pipe wrench

117

<u>ITEM NO.</u>	<u>QUANTITY</u>	<u>DESCRIPTION</u>
41	1	Bolt cutter
42	2	Electric hand drill
43	2	Heavy duty soldering gun
44	1	Hammer drill
45	1	Impact wrench kit
46	1	Jig saw
47	1	Bench grinder
48	1	Combination blower & vac system
49	1	Stud punch set
50	1	Drill press
51	1	Electric conduit bender
52	2	Stud gun
53	1	Threading machine
54	4	Pipe wrench
55	3	K.O. punch sets
56	8	Fiberglass step-ladders
57	1	Grease gun
58	6	Oil can
59	2	Chain wrench
60	2	Face shield
61	1	Welder
62	6	Propane torch kit
63	12	Ships auger
64	2	Wood bit set
65	2	Staple gun

<u>ITEM NO.</u>	<u>QUANTITY</u>	<u>DESCRIPTION</u>
66	1	Compact portable paint sprayer
67	1	Skill saw
68	1	Portable generator
69	6	Tube cutter
70	2	Bearing puller
71	1	Tap & die set
<u>SMALL TOOLS</u>		
72	16	Awl
73	16	Adjustable wrench
74	2	Allen wrench set
75	6	Wood chisel set.
76	16	Standard screwdriver
77	16	Phillips screwdriver
78	16	Offset screwdriver
79	16	Needle nose pliers
80	16	Vise-grip pliers
81	16	Diagonal cutting pliers
82	16	Side cutting pliers
83	16	Tongue-N-Groove pliers
84	16	Tool pouch
85	2	Handsaw
86	16	Electrician's knife
87	16	Nut drive set
88	2	Metal snips
	166	

<u>ITEM NO.</u>	<u>QUANTITY</u>	<u>DESCRIPTION</u>
89	16	Tool box w/tray
90	2	Ball pein hammer
91	2	Chisel and punch kit
92	2	Combination square
93	2	Cable cutter
94	16	Zig-zag rule
95	4	File
96	4	Steel bit
97	4	Round file
98	1	Screw extractor
99	16	Brace
100	2	Auger bit set
101	16	Claw hammer
102	2	Expansion bit
103	4	Fish tape
104	8	Wire stripper
105	1	Wood level
106	16	Fuse puller
107	2	Plastic hammer
108	2	Crowbar
109	2	Raw hide faced hammer
110	1	Socket set

MOTORS AND CONTROL DEVICES AND RELATED EQUIPMENT

111	1	AC Manual compensator
112	16	Electric motor Single phase split phase

<u>ITEM NO.</u>	<u>QUANTITY</u>	<u>DESCRIPTION</u>
113	16	Electric motor, three phase
114	8	Magnetic starter
115	6	Low voltage power supply
116	6	Instrument storage base
117	8	AC Magnetic starter, 3 pole
118	8	Pneumatic timing relay
119	8	AC Reversing magnetic starter
120	8	AC Magnetic contractor, single phase
121	8	AC Magnetic contractor, three phase
122	8	AC Manual drum switch
123	2	DC Magnetic relay
124	1	DC Contactor and starter
125	8	AC Magnetic relay
126	32	Standard duty control station
127	8	Repulsion start
128	8	Magnetic starter
129	4	Current transformer
130	8	Pneumatic timing relay
131	8	Electronic timing relay

121

<u>ITEM NO.</u>	<u>QUANTITY</u>	<u>DESCRIPTION</u>
<u>DISPLAYS AND MOCK-UPS (TEACHING AIDS)</u>		
132		Assortment of buzzers, bells, transformers
133	8	Zero speed switch
134		Assorted electric relays, motor starters, load centers, circuit breakers and contactors
135	2	Electronic switches
136	1	Vise
137	6	Workbench
138	2	Storage cabinet
139	1	Instructor's bench
140	1	Instrument storage cabinet
141	6	Steel shelving section
142	3	Shop stool
143	16	Shop box
144	2	Pipe rack

SPECIAL PURPOSE EQUIPMENT FOR SOLID STATE MOTOR CONTROL DEVICES

145	3	Power supply
146	16	Output amplifier
147	3	Input device, single phase, sine to square wave and unit reset
148	16	Logic function two-2 input "and" with standard and inverted outputs

<u>ITEM NO</u>	<u>QUANTITY</u>	<u>DESCRIPTION</u>
149	9	Logic function two-3 input "and" with standard output
150	6	Logic function one-6 input "and" with standard output
151	18	Logic functions two-3 input "or" with standard output
152	15	Logic functions two-1 input "not" with standard output
153	6	Logic functions one-3 input sealed "and" with standard and inverted output
154	6	Logic functions two-3 input "and-not" with standard output
155	9	Logic functions one "retentive memory" with standard and inverted output
156	9	Logic functions one "off-return memory" with standard and inverted output
157	3	Logic function "delay" (.04-12 sec.) with integral potentiometer
158	3	Logic functions "delay" (8-300 sec) with integral potentiometer
159	18	"Original input" devices, two 115 volt

123

<u>ITEM NO</u>	<u>QUANTITY</u>	<u>DESCRIPTION</u>
160	3	Power supply incoming AC line fitter
161	1	Wire terminal package of 500

124

171

SUPPLEMENTARY MATERIALS

FOR

ELECTRICAL INSTALLATION AND MAINTENANCE

125

172/173

AUDIO-VISUAL TRAINING AIDS

The following films are available from:

U.S.A.F. Central Audio-Visual Library
AF Audio-Visual Center
Norton A.F.B., California 92409

NOTE: All Air Force film requests should state that they are for professionally interested groups only and for training electrical apprentices.

TF 6181 Wire Size and Voltage Drop
TF 1-5163 Squirrel-Cage Rotor Principles
TF 1-5164 Split-Phase Motor Principles
TF 1-4375 Electricity and Magnetism - Part III - Voltaic Cell,
Dry Cell and Storage Battery
TF 1-4378 Electricity and Magnetism - Part II - Ohm's Law
TF 1-4514 Radio Technician Training - RCL - (Resistance, Capacitance,
Inductance)
TF 1-4521 Radio Technician Training - Elementary Electricity
TF 1-4653 Alternating Current - Part I
TF 1-4654 Alternating Current - Part II
TF 1-5202 Radio Technician Training - Elementary Electricity -
Amperes, Volts, and Ohms
TF 1-5250a Transistors - P-N Junction Fundamentals
TF 1-5250b Transistors - Triode Fundamentals
TF 1-5250c Transistors - Minority Carriers
TF 1-5250d Transistors - Low Frequency Amplifiers
TF 1-5250e Transistors - High Frequency Operation (Amplifiers and
Oscillators)
TF 1-5250f Transistors - Switching
TF 1-5250g Transistors - Servicing Techniques
TF 1-5443a Basic Electronics - Inductance in AC Circuits
TF 1-5443b Basic Electronics - Capacitance in AC Circuits
TF 1-5443c Basic Electronics - AC Series Circuits
TF 1-5443d Basic Electronics - AC Parallel Circuits
TF 1-5465a Fundamentals of Radio Troubleshooting - Principal
Technique
TF 6080 Motor Control Systems
TF 6082 Motor Controllers

174/175

126

AUDIO-VISUAL TRAINING AIDS

TOPIC	TITLE	MEDIA			PRICE	SOURCE
		FILMSTRIP	MOVIE	B/W		
Electric Cell	Electric Cell, The	X			4.95	Jam Handy
Electric Cell	Electric Cells and the Faraday Laws		X		300.00	Encyclopaedia Brit
Electric Cell	Lead Storage Battery: Dry Cell, The		X		300.00	Encyclopaedia Brit
Electric Cell	Story of the Modern Storage Battery, The		X		Loan	Serina Press
Electric Circuit, Parallel	Series and Parallel Circuits		X	X	70.00	Encyclopaedia Brit
Electric Circuit, Series	Series and Parallel Circuits		X	X	70.00	Encyclopaedia Brit
Electric Current	Electricity for Light and Heat	X			14.00	Curriculum Mat Corp
Electric Current	Static and Current Electricity	X			14.00	Curriculum Mat Corp
Electric Current	Alternating Current Theory- Lecture		X		300.00	Encyclopaedia Brit
Electric Current	Induced Electric Current - Lecture		X		300.00	Encyclopaedia Brit
Electric Current, Measurement	Electric Current Measurement	X		X	6.00	McGraw-Hill
Electric Current, Principle	Electric Current Principles	X		X	6.00	McGraw-Hill
Electric Generator	How Electricity is Produced	X			9.00	Soc for Visual Ed
Electric Heat	Electricity for Light and Heat	X			14.00	Curriculum Mat Corp
Electric Meter	Electric Meters	X			4.95	Jam Handy
Electric Motor	Electric Motors	X			14.00	Curriculum Mat Corp
Electric Motor	Electric Motors	X			4.95	Jam Handy
Electric Motor	Electric Motors - Lecture		X		300.00	Encyclopaedia Brit
Electric Motor	Study of Motors - Laboratory, A		X		300.00	Encyclopaedia Brit
Electric Motor	Electric Motors Part I, Magnetism and the DC Motor	X		X	.95	Vocat Agric Service

TOPIC	TITLE	MEDIA			PRICE	SOURCE
		FILMSTRIP	MOVIE	B/W		
Electric Motor	Electric Motors Part 2, Induction and the AC Motor	X		X	.95	Vocat Agric Service
Electric Motor	Electric Motors Part 3, Testing and Identifying Leads; Connecting and Reversing	X		X	1.00	Vocat Agric Service
Electric Motor	Electric Motors Part 4, Trouble Shooting	X		X	1.35	Vocat Agric Service
Electric Motor	Electric Motor - Parts 1 & 2	X		X	1.00	NASCO
Electric Motor, Generator	Principles of Electric Motors and Generators; The	X			6.00	Soc for Visual Ed
Electric Power	Wires to Our House		X		165.00	International Film
Electric Switch	Learning About Electric Current		X	X	52.50	Encyclopaedia Brit
Electrical Circuit	Electrical Circuits	X			6.00	Soc for Visual Ed
Electrical Circuit	Electric Circuits	X			6.00	Popular Science
Electrical Energy	Electrical Energy	X			6.00	McIntyre
Electrical Measurement	Measurement of Electricity		X	X	130.00	Coronet Films
Electrical Measurement	Measurement of Resistance	X			6.00	Popular Science
Electrical Resis- tance	Ohm's Law		X	X	65.00	Coronet Films
Electrical Safety	Electricity: Principles of Safety		X	X	130.00	Coronet Films
Electrical System Checking	Checking the Electrical System		X	X	30.50	US Natl A-V Ctr
Electrical Wiring	Diagraming for Electrical Wiring	X		X	1.48	NASCO
Electrical Wiring Conduit	Easy Does It		X		LOAN	Republic Steel
Electricity	What is Electricity	X			6.00	Benefic Press
Electricity	Series and Parallel Circuits		X	X	120.00	CENCO Educ Aids
Electric Power, Space	Electric Power Generation		X		LOAN	Serina Press

TOPIC	TITLE	MEDIA			PRICE	SOURCE
		FILMSTRIP	MOVIE	B/W		
Electricity	Sources of Electricity		X	X	X	120.00 CENCO Educ Aids
Electricity	Alternating Current	X			X	4.95 Jam Handy
Electricity	Applications (Part 1)	X			X	4.95 Jam Handy
Electricity	Applications (Part 2)	X			X	4.95 Jam Handy
Electricity	Basic Electricity (Ser 12)	X			X	52.60 Jam Handy
Electricity	Current Electricity	X			X	4.95 Jam Handy
Electricity	Electric Cell, The	X			X	4.95 Jam Handy
Electricity	Electric Meters	X			X	4.95 Jam Handy
Electricity	Electric Motors	X			X	4.95 Jam Handy
Electricity	Electromagnetism	X			X	4.95 Jam Handy
Electricity	Generator, The	X			X	4.95 Jam Handy
Electricity	Magnetism	X			X	4.95 Jam Handy
Electricity	Static Electricity	X			X	4.95 Jam Handy
Electricity	Storage Battery, The	X			X	4.95 Jam Handy
Electricity	Electrons		X	X		70.00 Encyclopaedia Brit.
Electricity	Physics Course Unit VI Electricity and Magnetism		X		X	5400.00 Encyclopaedia Brit
Electricity	Primary Cell, The		X	X		70.00 Encyclopaedia Brit
Electricity	Amperes, Volts, and Ohms		X	X		14.25 US Natl A-V Ctr
Electricity	Basic Electricity		X		X	LOAN Carrier Air Condit
Electricity	Basic Electricity		X		X	65.00 US Natl A-V Ctr
Electricity	Basic Electricity: AC Parallel Circuits		X	X		7.75 US Natl A-V Ctr
Electricity	Basic Electricity: AC Series Circuits		X	X		7.75 US Natl A-V Ctr
Electricity	Basic Electricity: Capacitance in AC Circuits		X	X		9.25 US Natl A-V Ctr
Electricity	Basic Electricity: Inductance in AC Circuits		X	X		12.50 US Natl A-V Ctr
Electricity	Electricity and Magnetism - Part I - Elements of Electricity		X	X		LOAN Serina Press
Electricity	Electricity: The Generator and the Motor		X		X	-- Universal Ed Vis Art

178

131

132

TOPIC	TITLE	MEDIA				PRICE	SOURCE
		FILMSTRIP	MOVIE	B/W	COLOR		
Electricity	Elements of Electricity		X	X		27.00	US Natl A-V Ctr
Electricity	Principles of Electricity		X		X	195.00	General Electric
Electricity, Current	Pressure and Current		X		X	150.00	Sterling Educ Films
Electricity Generation	Six Sources of Electricity		X	X		130.00	Prism Productions
Electricity, Insulator	Learning About Electric Current		X	X		52.50	Encyclopaedia Brit
Electricity, Magnetism	Magnetism		X		X	150.00	Sterling Educ Films
Electricity, Magnetism	How Magnets Produce Electricity		X	X		7.75	US Natl A-V Ctr
Electricity, Measurement	Electricity: Measurement		X	X	X	100.00	Indiana U A-V Ctr
Electricity, Physics	Alternating Current Theory - Lecture		X		X	300.00	Encyclopaedia Brit
Electricity, Physics	Capacitance - Lecture		X		X	300.00	Encyclopaedia Brit
Electricity, Physics	Coulomb's Law - Electrostatics Lecture		X		X	300.00	Encyclopaedia Brit
Electricity, Physics	Coulomb's Law - Magnetism - Laboratory		X		X	300.00	Encyclopaedia Brit
Electricity, Physics	Effects of Electric Currents - Lecture		X		X	300.00	Encyclopaedia Brit
Electricity, Physics	Electric Field and Potential - Lecture, The		X		X	300.00	Encyclopaedia Brit
Electricity, Physics	Electric Motors - Lecture		X		X	300.00	Encyclopaedia Brit
Electricity, Physics	Electrical Equivalent of Heat - Laboratory		X		X	300.00	Encyclopaedia Brit
Electricity, Physics	Electricity at Rest - Lecture		X		X	300.00	Encyclopaedia Brit

<u>TOPIC</u>	<u>TITLE</u>	<u>MEDIA</u>				<u>PRICE</u>	<u>SOURCE</u>
		<u>FILMSTRIP</u>	<u>MOVIE</u>	<u>B/W</u>	<u>COLOR</u>		
Electricity, Physics	Electricity in Motion - Lecture		X		X	300.00	Encyclopaedia Brit
Electricity, Physics	Electromotive Force of a Battery Cell-Laboratory		X		X	300.00	Encyclopaedia Brit
Electricity, Physics	Induced Electric Current - Lecture		X		X	300.00	Encyclopaedia Brit
Electricity, Physics	Magnetic Fields - Lecture		X		X	300.00	Encyclopaedia Brit
Electricity, Physics	Magnetic Induction - Lecture		X		X	300.00	Encyclopaedia Brit
Electricity, Physics	Magnetism - Lecture		X		X	300.00	Encyclopaedia Brit
Electricity, Physics	Ohm's Law - Lecture		X		X	300.00	Encyclopaedia Brit
Electricity, Physics	Parallel Circuits - Lecture		X		X	300.00	Encyclopaedia Brit
Electricity, Physics	Parallel Resistances - Laboratory		X		X	300.00	Encyclopaedia Brit
Electricity, Physics	Potential Divider - Laboratory, The		X		X	300.00	Encyclopaedia Brit
Electricity, Physics	Series Circuits - Laboratory		X		X	300.00	Encyclopaedia Brit
Electricity, Physics	Study of Motors - Laboratory		X		X	300.00	Encyclopaedia Brit
Electricity, Physics	Transformers - Lecture		X		X	300.00	Encyclopaedia Brit
Electricity, Physics	Transformer - Laboratory		X		X	300.00	Encyclopaedia Brit
Electricity, Physics	Wheatstone Bridge - Laboratory		X		X	300.00	Encyclopaedia Brit
Electricity, Source	Electrical Sources		X		X	150.00	Sterling Educ Films
Electricity, Static	Fundamentals of Electricity		X		X	150.00	Sterling Educ Films

TOPIC	TITLE	MEDIA				PRICE	SOURCE
		FILMSTRIP	MOVIE	B/W	COLOR		
Electricity, Teaching	A. C. and D. C. Generators	X		X		3.00	Long Filmslide
Electricity, Teaching	A. C. Voltmeters and Ammeters	X		X		3.00	Long Filmslide
Electricity, Teaching	Condensers and Choke Coils	X		X		3.00	Long Filmslide
Electricity, Teaching	D.C. Voltmeters and Ammeters	X		X		3.00	Long Filmslide
Electricity, Teaching	Electricity	X		X		20.00	Long Filmslide
Electricity, Teaching	Electricity at Work	X		X		3.00	Long Filmslide
Electricity, Teaching	Motors	X		X		3.00	Long Filmslide
Electricity, Teaching	Resistance	X		X		3.00	Long Filmslide
Electricity, Teaching	Transformers	X		X		3.00	Long Filmslide
Electricity, Transistor	Electronics: The Transistor.		X		X	- -	Universal Ed Vis Art
Electricity, Vacuum Tube	Electronics: Vacuum Tubes		X		X	- -	Universal Ed Vis Art
Electricity, Wiring	Electricity: Basic Wiring		X		X	- -	Universal Ed Vis Art
Electromagnetic Induction	Electromagnetic Induction Michael Faraday	X			X	6.95	Jam Handy
Electromagnetic Induction	Electromagnetic Induction		X	X	X	162.50	Coronet Films
Electromagnetic Induction	Fundamentals of A-C and D-C Generation		X		X	195.00	General Electric
Electromagnetism	Electromagnets and How They Work	X			X	5.95	Jam Handy
Electromagnetism	Electromagnetism	X			X	4.95	Jam Handy

181

TOPIC	TITLE	MEDIA			PRICE	SOURCE
		FILMSTRIP	MOVIE	B/W		
Electromotive Force	Current and Electromotive Force		X	X	19.25	US Natl A-V Ctr
Electromotive Force	Electron, The: An Introduction		X	X	28.50	US Natl A-V Ctr
Electromotive Force	What Causes Current Flow EMF		X	X	6.25	US Natl A-V Ctr
Electron	Electrons at Work		X		X	167.50 Encyclopaedia Brit
Electron	Fundamentals of Electricity		X		X	150.00 Sterling Educ Films
Electron	Magnetism		X		X	150.00 Sterling Educ Films
Electron	Discovery of the Electron - Lecture		X		X	300.00 Encyclopaedia Brit
Electron	Electrons		X	X		70.00 Encyclopaedia Brit
Electron	Electricity and Magnetism - Part 1 - Elements of Electricity		X	X		LOAN Serina Press
Electron	Electron, The: An Introduction		X	X		28.50 US Natl A-V Ctr
Electron, Circuit	Capacitance		X	X		53.50 US Natl A-V Ctr
Electron Flow Principles	Diode, The: Principles and Applications		X	X		30.50 US Natl A-V Ctr
Electron Theory	Current and Electromotive Force		X	X		19.25 US Natl A-V Ctr
Electron Theory	Electron Theory, The		X	X		9.25 US Natl A-V Ctr
Electron Theory, Diode Tube	Vacuum Tubes: Electron Theory and the Diode Tube		X	X		28.50 US Natl A-V Ctr

AUDIO-VISUAL AIDS SOURCES

- Benefic Press
10300 W Roosevelt Rd.
Wastchester, Ill. 60153
- Carrier Air Conditioning Company
Carrier Parkway
Syracuse, N. Y. 13201
- CENCO Educational Aids
2600 S. Kostner Avenue
Chicago, Ill. 60623
- Coronet Films
65 E. South Water St.
Chicago, Ill. 60601
- Curriculum Materials Corporation
1319 Vine Street
Philadelphia, Pa. 19107
- Encyclopaedia Britannica Educ. Corp.
425 North Michigan Avenue
Chicago, Ill. 60611
- General Electric Educational Films
60 Washington Ave.
Schenectady, N. Y. 12305
- Indiana University Audio-Visual Center
Field Services Department
Bloomington, Ind. 47401
- International Film Bureau, Inc.
332 South Michigan Avenue
Chicago, Ill. 60604
- Jam Handy School Service, Inc.
2781 East Grand Blvd.
Detroit, Michigan 48211
- Long FilmSlide Service
7505 Fairmont Avenue
El Cerrito, Calif. 94530
- McGraw-Hill Book Company
330 West 42nd Street
New York, N. Y. 10036
- McIntyre Educational Materials, LTD
3333 Metropolitan Blvd. East
Montreal 455, P.Q., Canada
- NASCO
Fort Atkinson
Wisconsin 53538
- Popular Science Publishing Company, Inc.
Audio-Visual Division
355 Lexington Avenue
New York, N. Y. 10017
- Prism Productions, Inc.
220 East 23rd Street
New York, N. Y. 10010
- Republic Steel Corporation
1436 Republic Building
Cleveland, Ohio
- Serina Press
70 Kennedy Street
Alexandria, Va. 22305
- Society for Visual Education, Inc.
1345 Diversay Parkway
Chicago, Ill. 60614
- Sterling Educational Films
241 East 34th Street
New York, N. Y. 10016
- United States National Audio-Visual Center
National Archives and Records Service
Washington, D. C. 20409
- Universal Educational and Visual Arts
221 Park Avenue South
New York, N. Y. 10003
- Vocational Agricultural Service
University of Illinois
434 Mumford Hall
Urbana, Ill. 61801

DEFINITION OF TERMS

For the purpose of clarifying the meanings of specific terms in this manual, the following words are defined.

Articulation - interrelation of different levels of education for ensuring continuous advancement in learning:

Associate in Applied Science Degree - the award given for the successful completion of a technical education curriculum.

Attitude - mental position, a feeling or an emotion toward a face of state; a predisposition to act in a certain way; a state of readiness that influences a person to act in a given manner.

Competency - sufficient judgement, skill and knowledge to perform a particular task.

Competency-Based Education - the educational process that specifies learning goals in measurable terms and requires that the learner achieve observable behavior changes in knowledge, skill and/or attitude to demonstrate competency before proceeding to more complex goals.

Competency-Based Instruction - the sequencing and modularization of curriculum into small, manageable units of instruction. The key concept is the student's ability to perform on each segment of the curriculum.

Criterion Measure - a statement of the predetermined standard to which an employee can perform, or must be able to perform, a given task. The criterion measures are those conditions used in evaluating job performance and the performance of the completed function.

Curriculum - a course or group of courses organized in a logical sequence to meet occupational education goals.

Diploma - an award for the successful completion of a course of study 64 to 128 quarter hour credits in length.

Educators - refer to individuals employed in educational institutions and in local, state, or federal agencies, both secondary and post-secondary.

Job Analysis - a detailed listing of tasks currently being performed by workers in a clearly defined, specific job.

Knowledge - the recall of specifics and universals, the recall of methods and processes and the recall of a pattern.

Learning Experience - an activity planned by educational institutions whereby the student can practice behavior implied by the objectives.

Occupational Survey - a procedure using mail questionnaires and/or personal interviews to gain knowledge of a community, educational interests or occupational needs to assist in planning.

Skill - the ability to use one's knowledge effectively and readily in execution or performance--dexterity or coordination in the execution of learned physical or mental tasks.

Syllabus - a course guide which includes overall and specific educational objectives; and arrangement of subject matter; learning experiences to give direction in meeting the stated objectives and texts and references. An illustration of evaluation techniques may be included.

Task - a logically related set of actions required for the completion of a job objective; also a task may be a complete job element.

Task Analysis - a study to determine the steps a worker must know and the key points of knowledge to know in order to perform a given task.

Technical Programs - consist of occupational-oriented courses and general education courses that lead to the awarding of an Associate in Applied Science Degree and prepare students for jobs in paraprofessional fields.

Understanding - the power to make experience intelligible by applying concepts and theories; the comprehension of ideas and the ability to use abstractions in particular and concrete situations.

Vocational Programs - systematic groups of courses or sequences of subjects designed to train students for skilled or semiskilled employment opportunities.